

# Ordering Information



**Example:** 12 - 1WA - 171MTG - 3: 12" Wafer Style Class 150 Carbon body, Straight 17-4 Ph SS Stem, 316 SS Nitrided Disc, Inconel® Seat, TFE Pkg, Garfil Bearings, Gear Operated

1. Size	Code	6. Disc Material	Code	11. Actuator Type	Code
2"	02	Alum Bronze/ENP B148 C958	0	Bare Shaft	B
2 ½"	025	<b>316 SS</b>	<b>2</b>	Worm Gear w/2" Square Nut & Hndwl	D
3"	03	Monel®	3	<b>Ratchet Handle</b>	<b>H</b>
3 ½"	035	Alum Bronze MIL-B-24480	5	Ratchet Handle w/Lock	L
4"	04	316 SS Nitrided	7	Throttle	T
to		Alum Bronze B148 ASTM C958	8	Worm Gear	3
48"	48	316 SS/ENP	9	Worm Gear (4-way keyed)	9
		2205 Duplex ASTM A890 Gr 4A	B	Pneumatic Double Acting	4
		Monel®/ENP	M	Pneumatic SR Fail Close	5
				Pneumatic SR Fail Open	6
				Hydraulic	7
				Electric	8
2. Body Class	Code	7. Shaft Material	Code	12. Special Feature	Code
150 PSI Max. Diff. Pressure	0	<b>17-4PH SS<sup>1</sup> w/DHT</b>	<b>D</b>	<b>None</b>	<b>O</b>
<b>ASME 150</b>	<b>1</b>	17-4PH SS <sup>1</sup>	1	Bi-directional	B
ASME 300	3	316 SS	2	Chlorine Service	C
ASME 600	6	Monel® <sup>1</sup>	3	Dead-end Service (DDES) <sup>2</sup>	D
		Inconel® 718/750	6	CE Marked (impact tested) <sup>3</sup>	PI
		Ferralium A479	7	CE Marked (non-impact tested) <sup>3</sup>	PN
		Nitronic 50	0	CE Marked (impact tested w/ vacuum service) <sup>3</sup>	VI
		ASTM B472 AL-6XN	A	CE Marked (non-impact tested w/ vacuum service) <sup>3</sup>	VN
3. Body Type	Code	8. Seat Material / O-Ring	Code	EF Seal (low emissions)	E
Wafer	W	TFE / Viton® <sup>4</sup>	T	EF Seal Vacuum Service (low emissions)	EV
Lugged	L	<b>RTFE / Silicone<sup>5</sup></b>	<b>R</b>	Silicone Free	G
<b>Lugged DDES<sup>2</sup></b>	<b>D</b>	RTFE / Viton® <sup>4</sup>	P	Epoxy Coated Body	H
		Polyethylene (UHMWPE) / Viton® <sup>4</sup>	L	Chainwheel	J
		Fire-Flow (TFE & Metal) / Viton® <sup>4</sup>	F	Stem Extension	K
		Fire-Flow (RTFE & Metal) / Viton® <sup>4</sup>	A	Lockable Gear	L
		Fire-Flow (RTFE & Metal) / Silicone	B	Limit Switch w/Stainless Steel Bolting	L1
		Inconel®	M	Limit Switch w/Monel® Bolting	L2
		Fire-Flow (TFE & Metal) / Silicone	J	Gear with Memory Stop	MS
				NACE Construction <sup>5</sup>	N
				NACE Construction	NI
				(w/CE marked impact tested) <sup>3,5</sup>	
				NACE Construction	NN
				(w/CE marked NON-impact tested) <sup>3,5</sup>	
				Buried Service	R
				Drill Through Lugs	T
				Drill Through Lugs and NACE Constr.	TN
				Vacuum Service	V
4. Shaft Design	Code	9. Packing Material	Code	Only select ONE special feature code per part number.	
<b>Straight</b>	<b>A</b>	<b>TFE</b>	<b>T</b>	13. Series	Code
Class ASME 150 2" - 12"		Graphite	G	<b>*Factory Assigned</b>	<b>J</b>
Class ASME 150 36" - 48"		Fire-Flow	F		
Class ASME 300 2" - 12" & 30"		Live-Load Packing/TFE	A		
Class ASME 600 2" - 8"		Live-Load Packing/Graphite	B		
Balanced	C	Live-Load Packing/Fire-Flow	C		
Class 150 14" - 30"		EF Seal (Viton® O-Rings)/TFE	D		
Derated 36" - 48" (150 psig max.)					
Class 300 14" - 24"					
Class 600 10" - 16"					
5. Body Material	Code	10. Bearing Material	Code		
<b>Carbon Steel</b>	<b>1</b>	<b>Garfil (Glass Backed TFE)</b>	<b>G</b>		
316 SS	2	316 SS Backed TFE	H		
Aluminum Bronze MIL-B-24480	5	Fire-Flow (Garfil & 316 SS)	F		
Aluminum Bronze B148 ASTM C958	8	Stainless Steel Nitrided	S		
2205 Duplex ASTM A890 Gr 4A	B	Bronze	B		
		Monel®	K		

**FLOWSEAL ACTUATOR OPTIONS:**

**Lever:**

- Not recommended for Metal Seat
- High Performance Butterfly Valve

**Worm Gear Operators:**

**Five types available:**

- High temperature service
- Buried service
- Submersible service
- Marine service
- Standard aluminum handwheel

**Optional:**

- Chain wheel
- Output shaft extension
- Input shaft extension
- Military special operator
- AWWA special operator

**Hydraulic Actuator:**

- Customer specified hydraulic actuator

**Pneumatic Actuators:**

- Crane Revo® spring return pneumatic actuator
- Crane Revo® double acting pneumatic actuator
- Customer specified pneumatic actuator

**Electric Actuators:**

- Series 44000 electric actuator
- Customer specified electric actuator

**Note<sup>1</sup>** Shaft materials other than 17-4 PH or Monel® will affect working pressure ratings. Please consult factory.  
**Note<sup>2</sup>** DDES = Double Dead End Service.  
**Note<sup>3</sup>** For CE marked valves, see Body Rating chart on page 18, as temp ranges can vary per material.  
**Note<sup>4</sup>** Viton® O-Ring is recommended for use in Hydrocarbon and NACE service.  
**Note<sup>5</sup>** RTFE/Silicone combination is not to be used with "NACE" valves.

Viton® is a registered trademark of DuPont Performance Elastomers L.L.C.  
Hastelloy C® is a registered trademark of Haynes International, Inc.  
Monel® and Inconel® is a registered trademark of Special Metals Corporation



# Dimensions Soft Seat

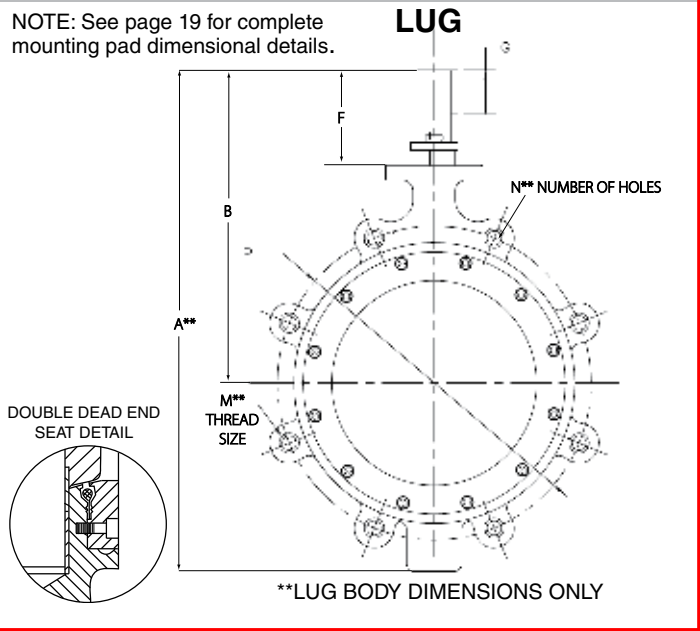
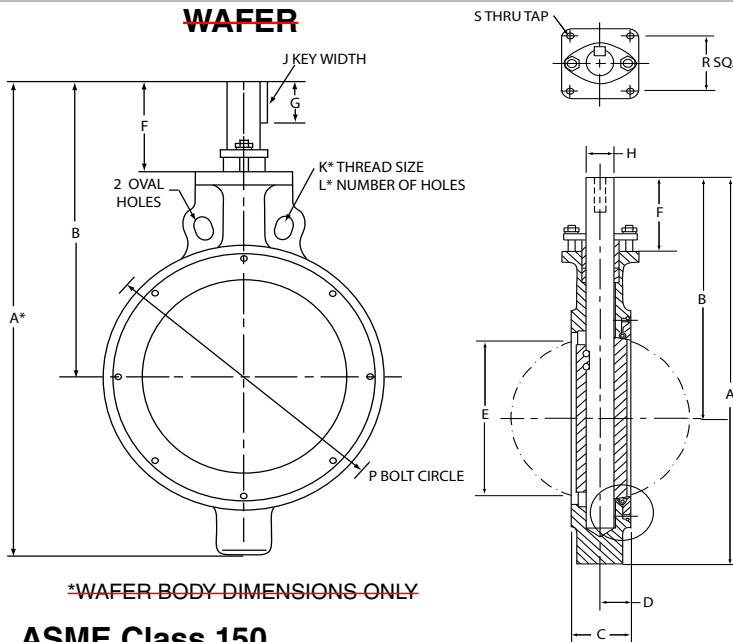

\*WAFER BODY DIMENSIONS ONLY

\*\*LUG BODY DIMENSIONS ONLY

## ASME Class 150

VALVE SIZE	WAFER	LUG	B	C	D	E	F	G	H	J	K*	L*	M**	N**	P	R	S	WEIGHT (LBS.)	
	A*	A**																WAFER	LUG
2"	10.59	10.59	7.59	1.75	1.06	1.72	3.34	.88	.500	3/16	-	-	5/8-11	4	4.750	2.25	3/8-16	8	11
2.5"	10.30	10.30	7.59	1.88	1.09	2.09	3.34	.88	.500	3/16	-	-	5/8-11	4	5.500	2.25	3/8-16	8	11
3"	11.60	11.98	8.60	1.92	1.20	2.75	3.60	1.19	.625	3/16	-	-	5/8-11	4	6.000	2.25	3/8-16	11	13
3.5"	11.97	11.97	8.72	2.05	1.30	3.19	3.60	1.19	.625	3/16	-	-	5/8-11	8	7.000	2.25	3/8-16	14	17
4"	12.92	13.55	9.42	2.13	1.26	3.62	3.67	1.19	.625	3/16	-	-	5/8-11	8	7.500	2.25	3/8-16	17	25
5"	14.53	15.16	10.28	2.25	1.34	4.55	3.81	1.25	.750	1/4	-	-	3/4-10	8	8.500	2.25	3/8-16	20	30
6"	15.69	15.93	10.81	2.29	1.38	5.55	3.81	1.25	.750	1/4	-	-	3/4-10	8	9.500	2.25	3/8-16	30	35
8"	17.81	17.94	11.93	2.50	1.49	7.28	3.80	1.25	1.000	3/8	-	-	3/4-10	8	11.750	2.25	3/8-16	44	48
10"	19.85	20.85	12.97	2.81	1.70	9.20	4.09	1.50	1.250	3/8	-	2	7/8-9	12	14.250	3.25	3/8-16	71	91
12"	24.96	24.96	15.46	3.23	1.86	11.15	4.83	2.25	1.500	3/8	-	2	7/8-9	12	17.000	3.25	3/8-16	110	127
14"	27.14	27.14	16.07	3.62	2.19	12.76	4.82	2.25	1.500	3/8	-	4	1-8	12	18.750	3.25	3/8-16	135	183
16"	31.66	31.66	19.61	4.00	2.31	14.58	6.92	2.50	1.750	1/2	-	4	1-8	16	21.250	4.25	1/2-13	182	250
18"	34.53	34.53	21.35	4.50	2.45	16.38	7.35	3.25	2.000	1/2	-	4	1-1/8-8	16	22.750	4.25	1/2-13	234	305
20"	36.70	36.70	22.76	5.00	2.94	18.38	7.63	3.00	2.250	3/4	1-1/8-8	4	1-1/8-8	20	25.000	5.00	3/4-10	320	414
24"	41.57	41.57	25.13	6.06	3.12	21.88	7.88	3.25	2.500	3/4	1-1/4-8	4	1-1/4-8	20	29.500	5.00	3/4-10	505	702
30"	52.08	52.08	29.35	6.75	3.53	28.00	8.73	4.50	3.000	3/4	1-1/4-8	4	1-1/4-8	28	36.000	5.00	3/4-10	925	1130
36"	64.75	64.75	32.64	8.38	4.34	33.66	8.14	3.50	3.750	1	1-1/2-8	4	1-1/2-8	32	42.750	7.00	1-8	1630	1890
42"	73.24	73.24	37.62	9.25	5.03	40.31	9.62	5.00	4.500	1	1-1/2-8	4	1-1/2-8	36	49.500	7.00	1-8	2475	2700
48"	80.13	80.13	41.88	10.62	5.62	45.25	10.63	6.00	5.000	1-1/4	1-1/2-8	4	1-1/2-8	44	56.000	9.00	1-8	2815	3085



# Pressure/Temperature Ratings **Soft Seat**

As temperature increases, the pressure retaining capability of materials decreases. The graph below illustrates the pressure/temperature ratings of the Flowseal ASME Class 150, Class 300, and Class 600.

The heavy lines define the ratings of the carbon steel and stainless steel valve body (or "shell") in conformance to ASME B16.34. The shaded areas define the ratings of the TFE and RTFE Seat materials.

Seat ratings are based on differential pressure with the disc in the fully closed position.\*

## Steam Service

TFE seated valves are rated for 50 psi saturated steam.

Valves with "O" seat configuration (RTFE seat / AFLAS O-ring) are rated to 100 psi steam service.

**ASME B16.34 Body and Flowseal Soft Seat Pressure - Temperature Ratings**

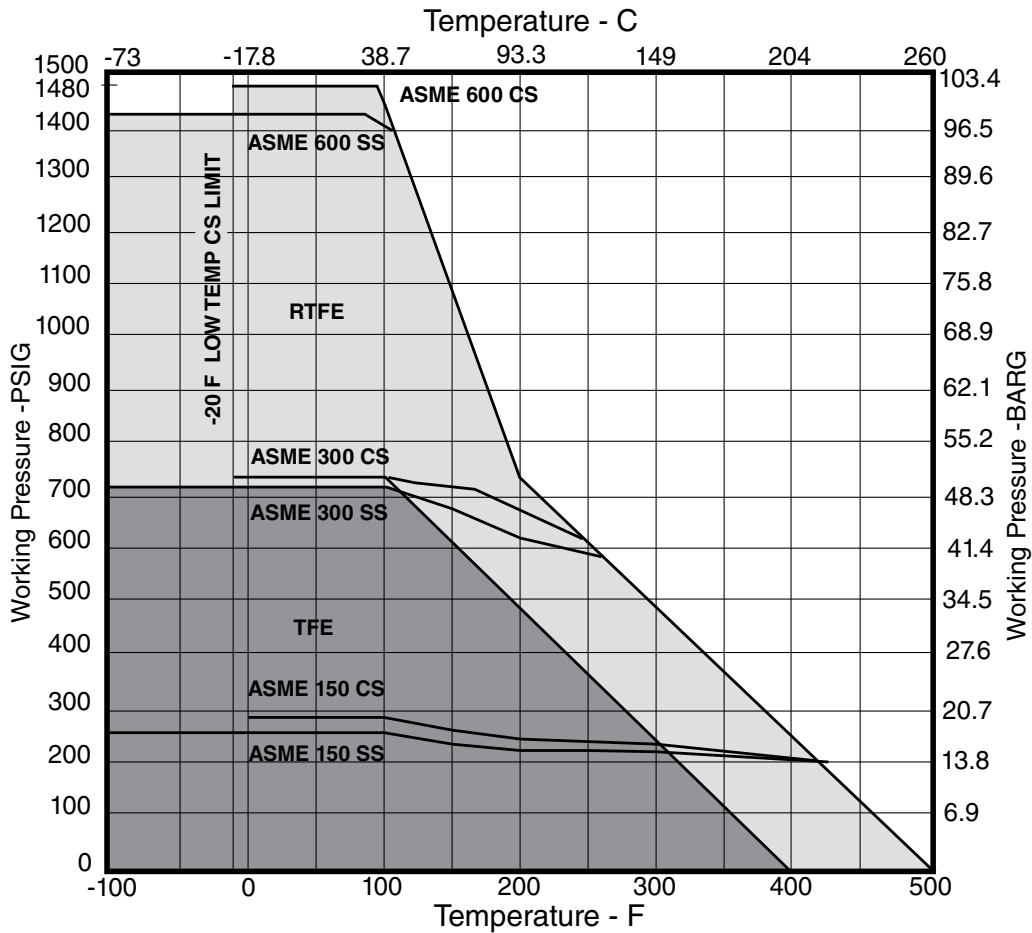

\*Shaft materials other than 17-4 PH or Monel® will affect working pressure ratings. Please consult factory.



# Valve Flow Coefficients

$C_v$  (Coefficient of Volume) is the number of U.S. gallons per minute of water required to pass through a valve with a pressure drop of 1 psi. The chart below records this  $C_v$  factor for the Flowseal valve classes and sizes at ten degree increments between open and closed. The values shown are for the valve installed in the seat upstream ("SUS") position.

Degree Open % Full $C_v$	10° 1.5%	20° 6%	30° 14%	40° 25.2%	50° 38%	60° 55%	70° 75%	80° 97%	90° 100%	
2"	150	1.5	6	14	25	39	56	76	99	102
	300	1.4	6	13	24	36	52	71	95	100
	600	1.4	5	13	23	35	51	70	90	93
2-1/2"	150	2.2	9	21	37	56	80	110	142	146
	300	2.1	8	19	34	52	75	102	136	143
	600	-	-	-	-	-	-	-	-	-
3"	150	3.4	14	32	57	87	125	171	221	228
	300	3.2	13	30	53	81	117	159	212	223
	600	3.1	12	29	52	79	114	156	202	208
3-1/2"	150	5.3	21	49	88	132	192	261	338	349
	300	4.8	19	45	80	121	176	240	320	336
4"	150	6.8	27	63	114	171	248	338	437	451
	300	6.2	25	58	104	157	228	310	414	435
	600	5.8	23	54	98	147	213	290	375	387
5"	150	10.8	43	100	180	271	392	535	692	714
	300	9.8	40	92	165	248	361	491	655	688
6"	150	16.5	66	154	278	419	607	827	1070	1103
	300	14.9	60	139	250	377	546	744	992	1041
	600	14.7	59	137	247	372	538	734	950	979
8"	150	30.9	124	289	520	784	1135	1584	2002	2064
	300	27.3	109	255	459	692	1001	1365	1820	1911
	600	26.8	107	250	451	679	983	1341	1734	1788
10"	150	52.8	211	492	886	1336	1934	2638	3411	3517
	300	45.6	183	426	767	1156	1673	2282	3042	3194
	600	41.2	165	384	692	1044	1511	2060	2665	2747
12"	150	72.6	290	677	1219	1838	2660	3628	4690	4837
	300	63.3	253	590	1063	1602	2319	3163	4217	4428
	600	58.4	233	545	981	1479	2140	2918	3774	3891
14"	150	90	392	914	1646	2481	3592	4898	6530	6857
	300	81	326	760	1368	2063	2986	4072	5430	5702
	600	73	292	682	1228	1838	2680	3655	4727	4873
16"	150	132	531	1230	2229	3361	4865	6634	8845	9287
	300	109	435	1015	1827	2755	3988	5438	7850	8243
	600	96	385	899	1619	2423	3533	4818	6231	6424
18"	150	171	684	1596	3873	4332	6270	8550	11270	11400
	300	139	555	1295	2331	3515	5088	6938	9250	9712
20"	150	207	828	1932	3478	5244	7590	10350	13800	14420
	300	158	630	1470	2646	3990	5775	7875	10150	10658
24"	150	315	1260	2940	5292	7890	11550	15750	21000	22050
	300	242	966	2254	4057	6118	8855	12075	16100	16205
30"	150	491	1965	4585	8253	12445	18012	24563	32750	34388
	300	404	1614	3766	6779	10222	14795	20175	26900	28245
36"	150	707	2830	6602	11884	17920	25938	35370	45745	47160
42"	150	963	3851	8987	16176	24392	35304	48143	62264	64190
48"	150	1258	5030	11738	21128	31859	46111	62881	81324	83840

## $C_f$ FACTORS

The critical flow factor,  $C_f$ , expresses the valve pressure recovery ratio. It is equivalent to  $F_L$  in ISA nomenclature.

Disc degree opening	15°	20°	25°	30°	35°	40°	45°	50°	55°	60°	65°	70°	75°	80°	85°	90°
Seat upstream	.95	.91	.84	.81	.78	.80	.77	.74	.74	.73	.70	.66	.63	.60	.57	.53
Seat downstream	.94	.89	.84	.82	.80	.77	.75	.72	.69	.66	.63	.60	.58	.55	.54	.53

# Valve Torque Tables Engineering Data

## ASME Class 150

### I. SEATING and UNSEATING TORQUE VALUES

(All Torques are in Inch Pounds)

VALVE SIZE	SOFT SEAT			
	SEAT UPSTREAM (SUS)		SEAT DOWNSTREAM (SDS)	
	0-150 PSIG	285 PSIG	0-150 PSIG	285 PSIG
3"	200	270	200	320
4"	225	470	410	610
6"	540	680	860	1320
8"	910	1620	1620	2580
10"	1620	2530	2630	4550
12"	2530	3600	4160	6350
14"	3720	5970	6200	9000
16"	5530	9180	9000	14700
18"	6840	11900	14500	20100
20"	10020	16970	18000	27200
24"	18330	32290	28100	43000
30"	32330	56930	45500	71800
36"	47000	81000	66000	102000
42"	65000	111000	92000	140000
48"	83000	146000	115000	184000

VALVE SIZE	FIRE-FLOW SEAT			
	SEAT UPSTREAM (SUS)		SEAT DOWNSTREAM (SDS)	
	0-150 PSIG	285 PSIG	0-150 PSIG	285 PSIG
3"	480	540	550	660
4"	645	770	800	1050
6"	1520	1740	2420	3380
8"	2350	2950	4180	4700
10"	4080	5100	6630	9200
12"	5830	7500	9600	13300
14"	9100	11300	15200	17000
16"	11900	16400	19400	26300
18"	17300	22100	36700	37400
20"	23700	34300	42600	55000
24"	36700	59800	56300	79600
30"	61200	89800	86100	113300
36"	C.F.	C.F.	C.F.	C.F.
42"	C.F.	C.F.	C.F.	C.F.

VALVE SIZE	METAL SEAT			
	SEAT UPSTREAM (SUS)		SEAT DOWNSTREAM (SDS)	
	0-150 PSIG	285 PSIG	0-150 PSIG	285 PSIG
3"	900	1250		
4"	1200	1550		
6"	2500	3200		
8"	3800	4700		
10"	6400	8700		
12"	8600	12800	CONSULT FACTORY	CONSULT FACTORY
14"	11200	15100		
16"	17800	24200		
18"	26100	32300		
20"	33500	47600		
24"	53000	71000		
30"	80500	115000		
36"	C.F.	C.F.		
42"	C.F.	C.F.		

Torques shown are for on/off applications and include sizing margins appropriate to normal liquid and gas applications. For severe services, or unusual fluids or slurries, consult factory.

### II. HYDRODYNAMIC TORQUE VALUES

The equal percentage flow characteristics of the Flowseal HPBV makes it well-suited for proportional control applications. Hydrodynamic valve torques develop as a result of the pipeline process conditions (media, velocity, pressure, temperature, and turbulence) and the shape and degree position of the valve disc. Under certain conditions, hydrodynamic torques can meet or exceed seating and unseating torques; when selecting actuators for throttling services, hydrodynamic torque must be considered to help ensure correct selection of actuation.

The chart below provides a  $C_t$  (Torque Coefficient) factor to aid in actuator sizing. The  $C_t$  factors are based on water at ambient temperature, and do not take into account other factors such as: cavitation, flashing, noise, vibration, etc. These considerations should be addressed prior to hydrodynamic torque sizing.

The equation for hydrodynamic torque is:

$$T_d = C_t \times \Delta P$$

$\Delta P$  = Pressure Drop in PSIG

$C_t$  = Torque Coefficient Factor

$T_d$  = Dynamic Torque in Inch Pounds

VALVE SIZE	10°	20°	30°	40°	50°	60°	70°	80°	90°
	C <sub>t</sub> = TORQUE COEFFICIENT FACTORS								
3"	1.23	1.59	2.56	4.00	6.25	9.09	14.29	12.99	15.87
4"	2.38	3.03	4.76	7.69	11.49	16.39	25.00	24.39	32.26
6"	5.00	7.69	14.29	24.39	43.48	71.43	111.11	100.00	125.00
8"	12.99	19.23	31.25	55.56	90.91	158.73	256.41	217.39	238.10
10"	22.73	34.48	55.56	100.00	166.67	277.78	454.55	384.62	416.67
12"	33.33	52.63	100.00	166.67	333.33	467.19	625.00	588.24	625.00
14"	35.71	55.56	90.91	158.73	256.41	454.55	714.29	625.00	769.23
16"	66.67	106.38	185.19	322.58	625.00	613.50	1333.33	1219.51	1351.35
18"	83.33	120.48	208.33	357.14	588.24	1000.00	1538.46	1333.33	1428.57
20"	126.58	196.08	344.83	588.24	1136.36	1724.14	2500.00	2272.73	2439.02
24"	200.00	322.58	588.24	1000.00	1960.78	2702.70	4000.00	3571.43	3846.14
30"	333.33	526.32	1000.00	1694.92	3333.33	4761.90	6666.67	5882.35	6250.00



# Body & Components Pressure/Temperature Ratings

## BODY RATING

The charts below reflect the pressure/temperature ratings for carbon steel and stainless steel valves, in accordance with ASME B16.34. The hydrostatic shell test is performed on the body at 150% of the cold working pressure (C.W.P. is defined as the pressure rating between -20 to 100°F [-28°C to 37°C]) and the hydrostatic seat test is performed on the disc and seat at 110% of the cold working pressure.

°F	Maximum Non-Shock Working Pressure-PSI								
	Carbon Steel <sup>(1)</sup>			Carbon Steel <sup>(2)</sup>			316SS		
ASME Class	150	300	600	150	300	600	150	300	600
<b>HYDROSTATIC SHELL TEST</b>	450	1125	2225	450	1125	2225	425	1100	2175
<b>HYDROSTATIC SEAT TEST</b>	315	815	1630	315	815	1630	305	800	1585
<b>-20 - 32</b>	285	740	1480	-	-	-	275	720	1440
<b>32-100</b>	285	740	1480	285	740	1480	275	720	1440
<b>200</b>	260	675	1350	260	675	1350	240	620	1240
<b>300</b>	230	655	1315	230	655	1315	215	560	1120
<b>400</b>	200	635	1270	200	635	1270	195	515	1030
<b>500</b>	170	600	1200	170	600	1200	170	480	955
<b>600</b>	140	550	1095	140	550	1095	140	450	905
<b>650</b>	125	535	1075	125	535	1075	125	445	890
<b>700</b>	110	535	1065	110	535	1065	110	430	865
<b>750</b>	95	505	1010	95	505	1010	95	425	845
<b>800</b>	80	410	825	80	410	825	80	415	830
<b>850</b>							65	405	810
<b>900</b>							50	395	790
<b>1000</b>							20	365	725

°C	Maximum Non-Shock Working Pressure-Bars								
	Carbon Steel <sup>(1)</sup>			Carbon Steel <sup>(2)</sup>			316SS		
ASME Class	150	300	600	150	300	600	150	300	600
<b>HYDROSTATIC SHELL TEST</b>	30	77	153	30	77	153	29	75	150
<b>HYDROSTATIC SEAT TEST</b>	22	56.9	112.4	22	56.9	112.4	20.9	54.6	109.3
<b>-29 to 0</b>	19.6	51.1	102.1	-	-	-	19.0	49.6	99.3
<b>0 to 38</b>	19.6	51.1	102.1	19.6	51.1	102.1	19.0	49.6	99.3
<b>50</b>	19.2	50.1	100.2	19.2	50.1	100.2	18.4	48.1	96.3
<b>100</b>	17.7	46.4	92.8	17.7	46.4	92.8	16.2	42.2	84.4
<b>150</b>	15.8	45.2	90.5	15.8	45.2	90.5	14.8	38.5	77.0
<b>200</b>	14.0	43.8	87.6	14.0	43.8	87.6	13.7	35.7	71.3
<b>250</b>	12.1	41.7	83.4	12.1	41.7	83.4	12.1	33.4	66.8
<b>300</b>	10.2	38.7	77.5	10.2	38.7	77.5	10.2	31.6	63.3
<b>350</b>	8.4	37.0	73.9	8.4	37.0	73.9	8.4	30.4	60.8
<b>400</b>	6.5	34.5	69.0	6.5	34.5	69.0	6.5	29.1	58.2
<b>425</b>	5.6	28.8	57.5	5.6	28.8	57.5	5.6	28.7	57.3
<b>450</b>							4.7	28.1	56.2
<b>500</b>							2.8	26.8	53.7
<b>525</b>							1.9	25.8	51.6

<sup>(1)</sup> CE impact tested materials and standard non-impact tested materials.  
<sup>(2)</sup> CE non-impact tested materials.

<sup>(1)</sup> CE impact tested materials and standard non-impact tested materials.  
<sup>(2)</sup> CE non-impact tested materials.

## COMPONENTS RATING

The chart at right reflects the maximum temperature ratings for individual components of the Flowseal HPBV.

Special care should be taken when specifying component materials for valves at elevated temperatures, especially metal seat valves.

Consult factory if additional information is required regarding the suitability of components for specific pressure/temperature applications.

Description & Material	Temperature	
	°F	°C
Seat Seal (Soft Seated)		
TFE	-100 to 400	-73 to 204
RTFE	-100 to 500	-73 to 260
UHMWPE	-100 to 200	-73 to 93
Seat Seal (Fire-Flow)		
TFE/Inconel®	-100 to 400	-73 to 204
RTFE/Inconel®	-100 to 500	-73 to 260
Seat Seal (Metal Seats)		
Inconel® 718	-100 to 1150	-73 to 621
316 Stainless Steel	-100 to 1000	-73 to 538
Seat O-Ring		
Silicone (Standard with RTFE)	-100 to 500	-73 to 260
Viton® (Standard with TFE)	-50 to 400	-46 to 204
Stem Packing		
TFE	-100 to 500	-73 to 260
Graphite	-100 to 1150	-73 to 621
Shaft		
17-4PH H1150	-100 to 800	-73 to 427
17-4PH H1150M	-100 to 800	-73 to 427
316 Stainless Steel	-100 to 1150	-73 to 621
K-Monel® 500	-100 to 1150	-73 to 621
Inconel® 718	-100 to 1150	-73 to 621
Bearings		
TFE/Fiberglass Composite	-100 to 500	-73 to 260
RTFE/316 Stainless Steel	-100 to 500	-73 to 260
Bronze	-100 to 750	-73 to 339
Steel	-100 to 1150	-73 to 621
316 Stainless Steel	-100 to 1000	-73 to 538
Disc Treatment		
Electroless Nickel Plating	-100 to 750	-73 to 399
Stellite	-100 to 1150	-73 to 621
Malcomizing	-100 to 900	-73 to 482

# Installation Instructions Engineering Data

## BOLTING DIMENSIONS

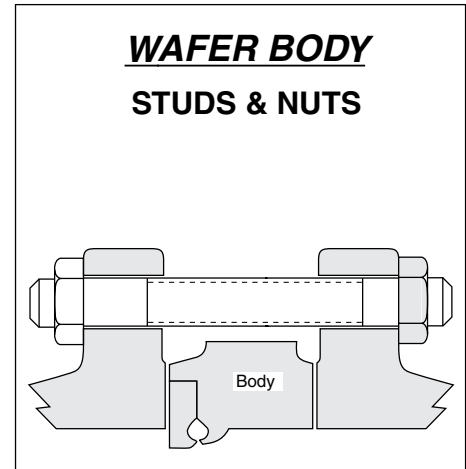
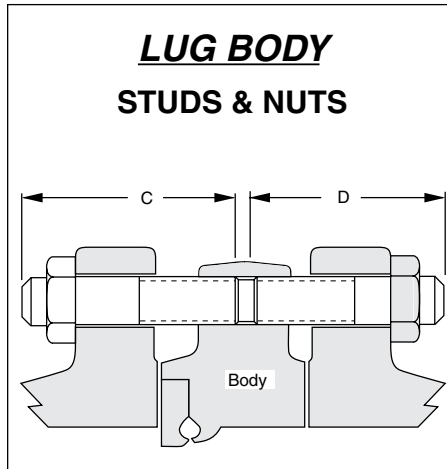
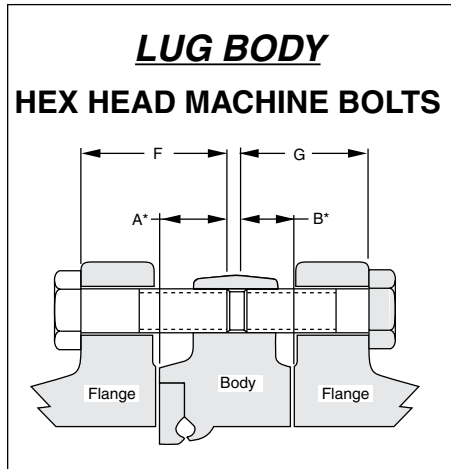

### ASME Class 150 2" – 24" MSS SP-44 Class 150 30" – 48"

VALVE SIZE	VALVE SERIES	THREAD SIZE	LUG VALVES												WAFER VALVES	
			BOLT ENGAGEMENT IN VALVE*				STUDS & NUTS				MACHINE BOLTS				STUDS & NUTS	
			QTY	LG	QTY	LG	QTY	LG	QTY	LG	QTY	LG	QTY	LG	QTY	LG
			A	A	B	B	C	C	D	D	F	F	G	G	E	E
2"	J	5/8-11	4	.940	4	.570	4	2.50	4	2.12	4	1.75	4	1.50	4	5.00
2 1/2"	J	5/8-11	4	.960	4	.680	4	2.62	4	2.38	4	2.00	4	1.62	4	5.25
3"	J	5/8-11	4	1.139	4	.725	4	3.00	4	3.00	4	1.88	4	1.62	4	6.00
4"	J	5/8-11	8	1.071	8	.745	8	3.00	8	3.00	8	2.00	8	1.62	8	6.00
5"	J	3/4-10	8	1.220	8	.790	8	3.12	8	2.62	8	2.25	8	1.75	8	6.00
6"	J	3/4-10	8	1.401	8	.839	8	3.50	8	2.75	8	2.38	8	1.75	8	6.50
8"	J	3/4-10	8	1.492	8	.948	8	3.75	8	3.00	8	2.50	8	2.00	8	6.50
10"	J	7/8-9	12	1.752	12	1.000	12	4.50	12	3.25	12	2.62	12	2.38	12	7.50
12"	J	7/8-9	12	2.147	12	1.025	12	4.50	12	3.25	12	3.38	12	2.25	12	8.00
14"	J	1-8	12	2.330	12	1.210	12	5.00	12	3.75	12	3.62	12	2.62	12	9.00
16"	J	1-8	16	2.648	16	1.270	16	5.25	16	4.00	16	4.00	16	2.62	16	10.00
18"	J	1 1/8-8	16	2.723	16	1.645	16	5.50	16	4.50	16	4.25	16	3.12	16	10.50
20"	J	1 1/8-8	16	3.396	20	1.434	16	6.25	20	4.50	16	5.12	20	3.19	16	11.00
	J	1 1/8-8	4**	2.325	-	-	4**	5.25	-	-	4**	4.06	-	-	8**	5.25
24"	J	1 1/4-8	20	3.690	20	2.250	20	6.75	20	5.25	20	5.50	20	4.12	20	12.50
30"	H	1 1/4-8	24	3.471	24	3.159	24	7.75	24	7.50	24	6.47	24	6.15	24	15.25
	H	1 1/4-8	4**	1.908	4**	1.592	4**	6.00	4**	5.75	4**	4.91	4**	4.59	8**	6.00
36"	H	1 1/2-8	28	3.760	28	3.740	28	9.00	28	9.00	28	7.19	28	7.19	28	18.25
	H	1 1/2-8	4**	1.760	4**	1.740	4**	6.75	4**	6.75	4**	5.25	4**	5.25	8**	6.75
42"	H	1 1/2-8	32	4.160	32	4.090	32	9.75	32	9.50	32	6.62	32	4.25	32	19.25
	H	1 1/2-8	4**	1.782	4**	1.718	4**	7.25	4**	7.25	4**	4.25	4**	4.25	8**	7.25
48"	H	1 1/2-8	40	5.520	40	4.850	40	11.75	40	11.00	40	9.83	40	9.16	40	21.00
	H	1 1/2-8	4**	2.815	4**	2.190	4**	7.75	4**	7.75	4**	7.12	4**	6.50	8**	7.75

Length of machine bolts based on:

1. Gasket thickness of 0.06 inches.
2. Minimum flange thickness of weld neck flanges per ASME B16.5.

Every effort is made to provide accurate information, but no liability for claims arising from erroneous data will be accepted by Flowseal.