



Series 200 Figure Number System

Series 200 1 1 2 3 4 5 6 7 8 9 — 10

1. Size	Code	5. Disc	Code	9. Actuator	Code
2"	02	Ductile Iron-ENP (2"-12")	2	Handle (10 positions)	2
2½"	25	316 SS	4	Infinite/Lockable (2"-6") (10 positions)	3
3"	03	Ductile Iron (14"-48")	5	Infinite (8")	4
to		Aluminum Bronze (2"-48")	6	Gear Operator	5
48"	48	Monel® 400	7	Double Acting	6
				Fail Close (SR)	7
				Fail Open (SR)	8
				Electric	9
				Gear Operating/Balancing	G
				Buried Gear/2" Nut	C
				Chain Wheel	U
				None	X
2. Series/Style	Code	6. Shaft	Code	10. Special Features	Code
Wafer (2"-30")	A	416 SS	1	Custom Product	D
Lug (2"-30")	B	316 SS*	4	CE Marked - Non-Impact Tested	P
Lug/Deadend (2"-30")	C	Monel® 400	7		
Flange (28"-48")	D	17-4 PH	9		
3. Body	Code	*Standard with 316SS Disc only.			
Epoxy Coated CI (A126) (2"-12")	S	7. Bushing	Code		
Epoxy Coated DI (A536) (2"-12")	V	Bronze	0		
Cast Iron (A126) (2"-30")	1	PTFE	3		
Ductile Iron (A536) (14"-48")	2	8. Seat/Liner	Code		
Ductile Iron (A395) (2"-48")	G	Buna-N	1		
		Abrasion Resistant Buna-N	2		
		Black Neoprene	3		
		EPDM	5		
		Viton® (275°F)	6		
		Perox. Cured Buna-N	8		
		PTFE/Buna-N**	L		
		Viton® (400°F)	P		
		EPDM (FDA)	V		
		White Buna-N (FDA)	W		
		Potable water EPDM	D		
		White Buna-N	B		

** 2½" and 5" PTFE/Buna-N not available.

NOTE: For ASTM designations see Bill of Materials page 6.



Series 200 Overview

- Available in sizes 2" to 48".
- Available in Wafer or Lug style body (2" to 30").
- Double flange available 28" to 48" valves.
- Wafer body features four alignment holes.
- Pressure ratings for tight shutoff at temperatures up to the maximum limit of the seat material:
 - 2" to 12" — 200 psi, 125 psi for PTFE/Buna seat.
 - 14" to 48" — 150 psi.
- Ideal for on-off or throttling services.
- Available with handles (2" to 12"), manual gear operators (2" to 48"), and electric or pneumatic actuators (2" to 48").
- Refer to Crane automation bulletin for details of pneumatic and electric actuators.
- Designed to comply with MSS SP-67 and MSS SP-25.
- Compatible with ASME B16.1 and ASME B16.5 flanges.
- Valves 2" to 20" meet the intent and have passed the AWWA C-504-87 Section 5 proof of design tests.
- Type approval certification from ABS & USCG Category A for marine applications (2" to 48").
- Bi-directional dead-end capability to 200 psi (2" to 12") and 150 psi (14" to 24") is standard on lug valves.
- Operators mounted perpendicular to pipe.
- For bolting information, consult the Center Line Installation and Maintenance Manual.
- Vacuum Service Rating: zero leakage at 24" of mercury.
- Commercial cleaning available for Oxygen level 2.
- CE/PED Certification available for sizes 2" to 24".

Valve Seating Torques (In-Lbs.) 2" to 30"

Valve Size	Standard Disc Differential Pressure								Undercut Differential Pressure	
	50 PSI ΔP Bushing		100 PSI ΔP Bushing		150 PSI ΔP Bushing		200 PSI ΔP Bushing		75 PSI ΔP Bushing	
	Bronze	PTFE	Bronze	PTFE	Bronze	PTFE	Bronze	PTFE	Bronze	PTFE
2"	106	100	117	106	129	111	140	117	-	-
2 ½"	152	150	166	163	181	176	195	189	-	-
3"	213	207	230	220	248	232	265	244	-	-
4"	321	290	386	323	450	357	515	390	-	-
5"	481	423	598	481	715	540	832	598	-	-
6"	692	599	878	691	1,063	783	1,248	875	-	-
8"	1,326	1,060	1,716	1,183	2,106	1,307	2,496	1,430	1,124	819
10"	2,239	1,671	3,010	1,872	3,780	2,074	4,550	2,275	1,363	909
12"	3,959	2,568	4,953	2,795	5,948	3,023	6,942	3,250	2,457	1,445
14"	4,881	2,640	6,226	3,070	7,570	3,500	-	-	4,400	2,300
16"	7,020	4,260	8,580	4,880	10,140	5,500	-	-	5,900	3,600
18"	10,105	6,287	12,202	7,243	14,300	8,200	-	-	8,300	5,500
20"	13,923	8,360	16,582	9,180	19,240	10,000	-	-	11,100	6,700
24"	23,617	15,427	26,953	16,813	30,290	18,200	-	-	17,300	12,100
30"	39,721	27,313	43,391	29,407	47,060	31,500	-	-	27,300	21,100

Valve Seating Torques (In-Lbs.) 28" to 48" Double Flanged

Valve Size	Standard Disc Differential Pressure		
	50 PSI Wet	100 PSI Wet	150 PSI Wet
28"	23,718	26,639	28,957
30"	28,320	30,860	33,338
32"	32,418	35,073	38,126
36"	40,622	43,480	46,524
40"	68,924	74,048	78,995
42"	69,747	74,632	79,862
48"	96,598	103,837	111,112

All torques shown in these charts were derived from test data using water at 60°F. For torques using dry gases, multiply these numbers by 2.0. For torques involving other media, please consult the factory.

There is no safety factor included in the numbers shown on these charts. For actuator sizing, Crane recommends that these values be multiplied by 1.2 for single valve applications, or 2.0 for 3-way ("tee") applications.

For PTFE/Buna seats multiply the numbers shown by 2.0.

Under certain conditions, hydrodynamic torque can meet or exceed seating and unseating torques. When designing valve systems, hydrodynamic torque must be considered to help assure correct selection for the application.

Series 200 Temperature Ratings and Cv Values

Seat Temperature Ratings

Material	Temperature Ratings °F
Buna-N	+10 to 180
Abrasive Resistant Buna-N	+10 to 180
Neoprene	+20 to 200
EPDM (2" - 16")	-30 to 275
EPDM (18" & Above)	-30 to 225
EPDM, Food Grade (2" - 12")	-30 to 225
Viton®	+10 to 275
High Temp. Viton®	+10 to 400
PTFE over Buna-N (125 psi, 2" - 12")	+40 to 250

Although elastomers have an effective operating temperature range, when used in valves, these ranges may have to be modified. The temperature ranges shown in the table have been adjusted accordingly.

For Low Temperature: While the seat materials selected for use in Center Line butterfly valves are capable of withstanding lower temperatures without damage, the durometer of the elastomer is changed. This “hardening” of the seat may increase the operating torque beyond the structural limits of the stem and/or the disc to stem configuration.

For High Temperature: When using High Temperature Viton®, the operating pressure of the valve is reduced above 275°F.

Field Replacement: Replacing seats in sizes 14" and above requires factory service.

C_v Values – Valve Sizing Coefficients (US-GPM @ 1ΔP) 2" to 48"

Size	10°	20°	30°	40°	50°	60°	70°	80°	90°
2"	0.06	3	7	15	27	44	70	105	115
2 ½"	0.10	6	12	25	45	75	119	178	196
3"	0.20	9	18	39	70	116	183	275	302
4"	0.30	17	36	78	139	230	364	546	600
5"	0.50	29	61	133	237	392	620	930	1022
6"	0.80	45	95	205	366	605	958	1437	1579
8"	2	89	188	408	727	1202	1903	2854	3136
10"	3	151	320	694	1237	2047	3240	4859	5340
12"	4	234	495	1072	1911	3162	5005	7507	8250
14"	6	338	715	1549	2761	4568	7230	10844	11917
16"	8	464	983	2130	3797	6282	9942	14913	16388
18"	11	615	1302	2822	5028	8320	13168	19752	21705
20"	14	791	1647	3628	6465	10698	16931	25396	27908
24"	22	1222	2587	5605	9989	16528	26157	39236	43116
28"	36	1813	3639	6636	10000	14949	22769	34898	49500
30"	37	2080	4406	9546	17010	28147	44545	66818	73426
32"	45	2387	4791	8736	13788	20613	31395	48117	38250
36"	260	3050	6730	12740	20220	32500	52500	79600	87500
40"	84	4183	8395	15307	24159	36166	55084	84425	119750
42"	350	4095	9040	17108	27150	43640	70500	106890	117500
48"	455	5365	11840	22400	30600	51200	92300	140000	154000

Series 200 Dimensions

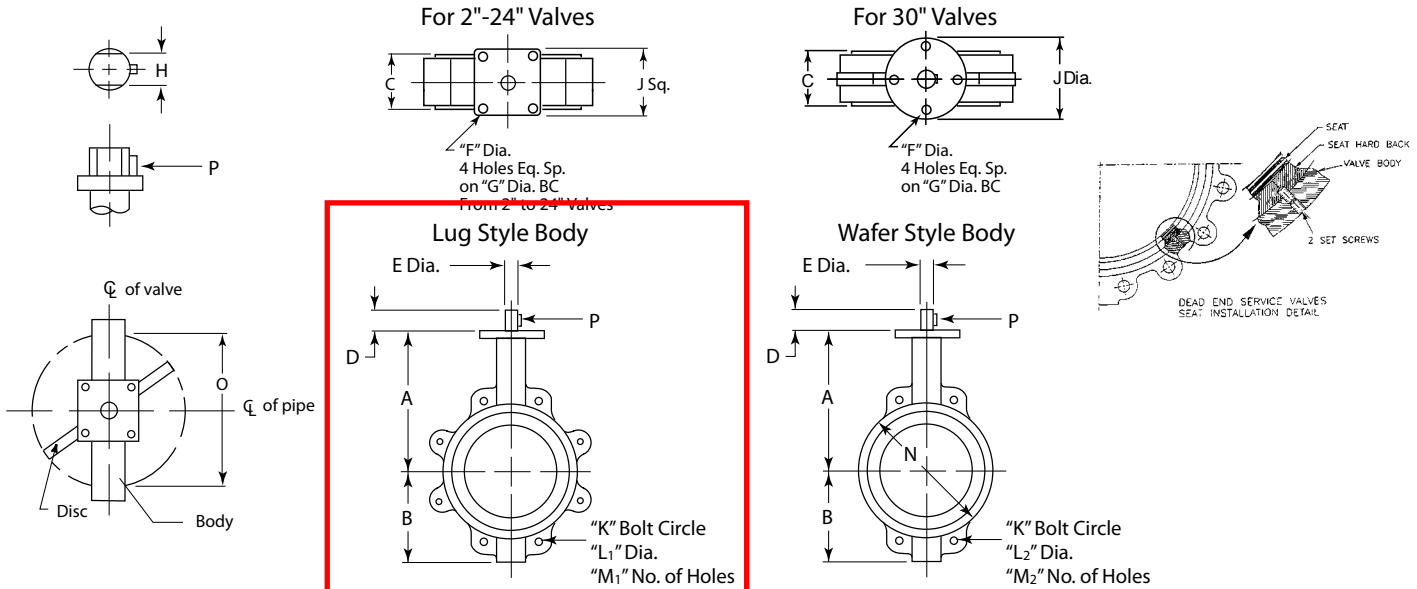

Dimensions 2" - 30" Wafer and Lug

For installation and maintenance instructions, please refer to the IOM manual available at www.cranevalveit.com

Inches / mm	A	B	C	D	E	F	G	H	J	K	L ₁	L ₂	M ₁	M ₂	N	O	P
2" 50	6 3/8 161.93	3 3/16 80.96	1 1/8 47.63	1 1/4 31.75	1/2 12.70	3/8 9.53	2.76 70	0.39 10	2 3/4 69.85	4 3/4 120.65	5/8-11 17.46	11/16 17.46	4	4	4 101.60	1.26 32.0	Woodruff #3
2 1/2" 65	6 7/8 174.63	3 1/2 88.90	2 50.80	1 1/4 31.75	1/2 12.70	3/8 9.53	2.76 70	0.39 10	2 3/4 69.85	5 1/2 139.70	5/8-11 17.46	11/16 17.46	4	4	4 3/4 120.65	1.83 46.5	Woodruff #3
3" 80	7 1/8 180.98	3 3/4 95.25	2 50.80	1 1/4 31.75	1/2 12.70	3/8 9.53	2.76 70	0.39 10	2 3/4 69.85	6 152.40	5/8-11 17.46	11/16 17.46	4	4	5 127.00	2.54 64.5	Woodruff #3
4" 100	7 7/8 200.03	4 1/2 114.30	2 1/8 53.98	1 1/4 31.75	5/8 15.88	3/8 9.53	2.76 70	0.47 12	2 3/4 69.85	7 1/2 190.50	5/8-11 17.46	11/16 17.46	8	4	6 1/4 158.75	3.54 89.9	Woodruff #9
5" 125	8 3/8 212.73	5 127.00	2 3/8 60.33	1 1/4 31.75	3/4 19.05	3/8 9.53	2.76 70	0.55 14	2 3/4 69.85	8 1/2 215.90	3/4-10 20.64	13/16 20.64	8	4	7 1/2 190.50	4.36 110.7	Woodruff #9
6" 150	8 7/8 225.43	5 1/2 139.70	2 3/8 60.33	1 1/4 31.75	3/4 19.05	3/8 9.53	2.76 70	0.55 14	2 3/4 69.85	9 1/2 241.30	3/4-10 20.64	13/16 20.64	8	4	8 3/8 212.73	5.72 145.3	Woodruff #9
8" 200	10 1/4 260.35	6 1/8 174.63	2 1/2 63.50	1 3/4 44.45	7/8 22.23	7/16 11.11	4.02 102	0.67 17	3 3/4 95.33	11 3/4 298.45	3/4-10 20.64	13/16 20.64	8	4	10 3/8 269.88	7.6 193.0	Woodruff #9
10" 250	11 1/2 292.10	8 203.20	2 3/4 69.85	1 3/4 44.45	1 1/8 28.58	7/16 11.11	4.02 102	0.87 22	3 3/4 95.33	14 1/4 361.95	7/8-9 23.81	15/16 23.81	12	4	12 1/8 327.03	9.5 241.3	Woodruff #15
12" 300	13 1/4 336.55	9 5/8 244.48	3 1/8 79.38	1 3/4 44.45	1 1/4 31.75	7/16 11.11	4.02 102	0.95 24	3 3/4 95.33	17 431.80	7/8-9 23.81	15/16 23.81	12	4	15 7/8 403.23	11.45 290.8	Woodruff #15
14" 350	14 1/2 368.30	10 1/2 266.70	3 1/8 79.38	1 3/4 44.45	1 1/4 31.75	7/16 11.11	4.02 102	0.95 24	3 3/4 95.33	18 3/4 476.25	1-8 26.99	1 1/16 26.99	12	4	17 1/8 434.98	12.78 324.6	Woodruff #15
16" 400	15 3/4 400.05	12 7/8 327.02	3 1/2 88.90	2 50.80	1 5/16 33.34	7/8 22.23	6.50 165	1.06 27	6 1/2 165.10	21 1/4 539.75	1-8 26.99	1 1/16 26.99	16	4	19 1/4 488.95	14.97 380.2	5/16" Sq. x 1 3/4"
18" 450	16 5/8 422.28	13 5/8 346.08	4 1/4 107.95	2 50.80	1 1/2 38.10	7/8 22.23	6.50 165	1.06 27	6 1/2 165.10	22 3/4 577.85	1 1/8-7 31.75	1 1/4 31.75	16	4	21 1/4 539.75	16.83 427.5	3/8" Sq. x 1 1/2"
20" 500	18 7/8 479.43	15 1/8 384.18	5 3/8 136.53	2 3/4 63.50	1 5/8 41.28	7/8 22.23	6.50 165	1.26 32	6 1/2 165.10	25 635.00	1 1/8-7 31.75	1 1/4 31.75	20	4	23 5/8 650.88	18.67 474.2	3/8" Sq. x 1 3/4"
24" 600	22 7/8 561.98	18 3/8 466.73	6 1/8 155.58	2 3/4 69.85	2 50.80	7/8 22.23	6.50 165	1.42 36	6 1/2 165.10	29 3/4 749.30	1 1/4-7 34.93	1 3/8 34.93	20	4	27 1/8 708.03	22.62 574.5	1/2" Sq. x 2 1/4"
30" 750	25 1/2 647.70	24 3/4 628.65	6 3/4 171.45	3 1/4 82.55	2 1/2 63.50	7/8 22.23	8 1/2 215.90	N/A	11 1/4 285.75	36 914.40	1 1/4-7 31.75	1 1/4 31.75	28	4	34 3/8 873.13	28.6 726.4	5/8" Sq. x 2 5/8"

L₁ and M₁ refer to Lug style valves, L₂ and M₂ refer to Wafer Style. "C" dimension is listed with elastomer in the relaxed condition. Approximately 1/8" total compression is required for proper sealing with pipe flanges. Valves are designed for installation between ASME B16.1 Class 125 (Iron) and B16.5 Class 150 (Steel) flanges. Gaskets are not needed, and should not be used since the seat face seals against the mating flange. If the valve is to be installed in between any other flanges, consult your Center Line agent or the factory for additional information. Center Line recommends that a blind flange be used on end of line applications.

"O" dimension is the valve clearance dimension.

Series 200 Materials of Construction

Sizes 2"-30"

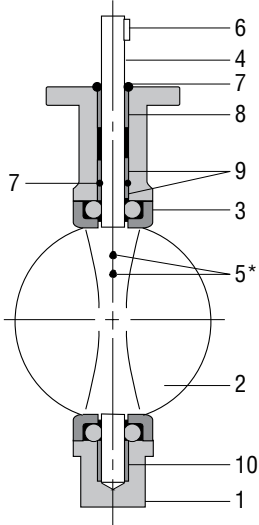

*Quantity of 3 pins required for 30" lug or wafer style valves.

Sizes 28"-48"

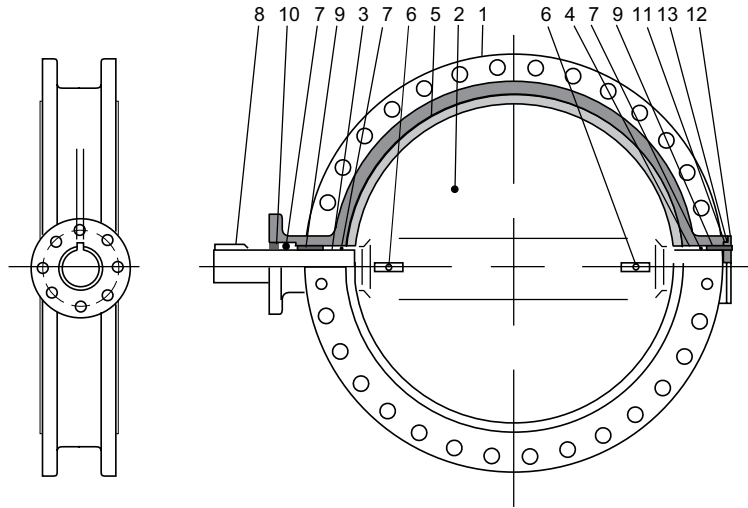

Bill of Materials 2" - 30"

Item	Description	Materials	Optional Materials
1	Body	Ductile Iron (A536 65-45-12)	Ductile Iron (A536 65-45-12), (A395 60-40-18)
2	Disc	Ductile Iron[†] (A536 65-45-12)	Aluminum Bronze (B148-C954), 316 SS (A351-CF8M), Monel® (A494-M30C)
3	Seat	Buna-N or EPDM	Neoprene, Viton®, PTFE, FDA, Abrasion-Resistant
4	Shaft	416 Stainless Steel (A582-416)	316 Stainless Steel (A276/A479-316), Monel® (B164-K400-CL-B), 17-4PH (A564-630/1150)
5	Taper Pins	416 Stainless Steel (A582-416)	316 Stainless Steel (A276/A479-316), Monel® (B164-K400-CL-B), 17-4PH (A564-630/1150)
6	Key	Carbon Steel	No Option Available
7	O-Ring	Buna-N	No Option Available
8	Bushing	PTFE	Luberized Bronze
9	Bushing	PTFE	Luberized Bronze
10	Bushing	PTFE	Luberized Bronze

[†]ENP plated for 2"-12" valves

Bill of Materials 28" - 48"

Item	Description	Materials	Optional Materials
1	Body	Ductile Iron (A536 65-45-12)	Ductile Iron (A395 60-40-18)
2	Disc	Ductile Iron (A536 65-45-12)	Aluminum Bronze (B148-C954), 316 SS (A351-CF8M)
3	Upper Shaft	416 Stainless Steel (A582-416)	316 SS (std. w/ 316 SS disc) (A276/A479-316)
4	Lower Shaft	416 Stainless Steel (A582-416)	316 SS (std. w/ 316 SS disc) (A276/A479-316)
5	Seat	Buna-N or EPDM	Viton®
6	Taper Pin	416 Stainless Steel (A582-416)	316 Stainless Steel (A276/A479-316)
7	O-Ring	Buna-N	No Option Available
8	Key	Carbon Steel	No Option Available
9	Bushing	TFE	Luberized Bronze
10	Bushing	TFE	Luberized Bronze
11	Thrust Washer	TFE	Luberized Bronze
12	End Plate	Ductile	No Option Available
13	O-Ring	Buna-N	No Option Available

Monel® is a registered trademark of Special Metals Corporation.

Technical Data

The nomograph on the next page gives the relationships of valve size, flow, velocity, and pressure drop for various disc positions.

Sample Calculation, Liquid (see black line on chart)

Given:

Water (1.0 specific gravity) at 60°F is flowing through a 6-inch valve at a rate of 1000 gpm.

Find:

Line velocity (ft./sec.) and pressure drop when valve is in full-open (disc at 90°) position.

Solution:

From the 6-inch valve size at lower left of nomograph, go diagonally up to the intersecting horizontal line for 1000 gpm. From that point, proceed directly down to determine line velocity as 11 ft./sec.

For pressure drop, return to the 1000 gpm intersection and continue up vertically to "90° disc open" intersecting diagonal line. From this point, go horizontally to the left to determine pressure drop as 0.5 psi.

Size	C _v at Full-Open
2"	115
2 ½"	196
3"	302
4"	600
5"	1022
6"	1579
8"	3136
10"	5340
12"	8250
14"	11917
16"	16388
18"	21705
20"	27908
24"	43116
30"	73426

Sample Calculation, Gas (see gray line on chart)

Given:

Gas (0.8 lb/cu. ft. density) is flowing through an 8-inch valve at a rate of 1500 cu. ft./min.

Find:

Line velocity (ft./min.) and pressure drop when valve is in full-open (disc at 90°) position.

Solution:

From 8-inch valve size at lower left of nomograph, go diagonally up to the intersecting horizontal line for 1500 cu. ft./min. From that point, proceed directly down to the bottom line of the nomograph to determine line velocity as 4000 ft./min.

For pressure drop, return to the 1500 cu. ft./min. intersection and continue up vertically to "90° disc open" intersecting diagonal line. From this point, go horizontally to the left to determine pressure drop as 17 psi. Now, convert pressure drop to gas by dividing gas density by liquid density and multiplying by 17.

General Notes

- Liquid flow data is based on pressure drop and flow rate with viscosity similar to water at 60°F using flow coefficient.

$$\frac{0.8}{62.34} \times 17.0 = 0.22 \text{ psi}$$

- Velocities for liquids with densities similar to water should be less than 16 ft./sec.
- Nomograph flow rate for gases is in cubic feet per minute (CFM) at flowing conditions. To convert flow rate from standard cubic feet per minute to CFM, use the following formula:
- Gas density in lbs./cu. ft. equals:

$$\text{CFM} = \frac{(\text{SCFM} \times 14.7) \times (460 + ^\circ\text{F})}{(\text{line pressure, psia}) \times 520}$$

$$\left(\frac{270 \times}{\text{line pressure, psia}} \right) \times \left(\frac{\text{specific gravity of gas (relative to air)}}{460 + ^\circ\text{F}} \right)$$

Definitions

C_v = Flow coefficient for valves; expresses flow rate in gallons per minute of 60°F water with 1.0 psi pressure drop across valve.

K = resistance coefficient.

$$\mathbf{K} = d \sqrt{\frac{29.9}{C_v}}$$

P = weight density of fluid, in pounds per cubic foot.

d = internal diameter of Schedule 40 pipe, in inches.

Q = rate of flow, in gallons per minute.

ΔP = differential pressure, in pounds per square inch gauge.

Technical Data

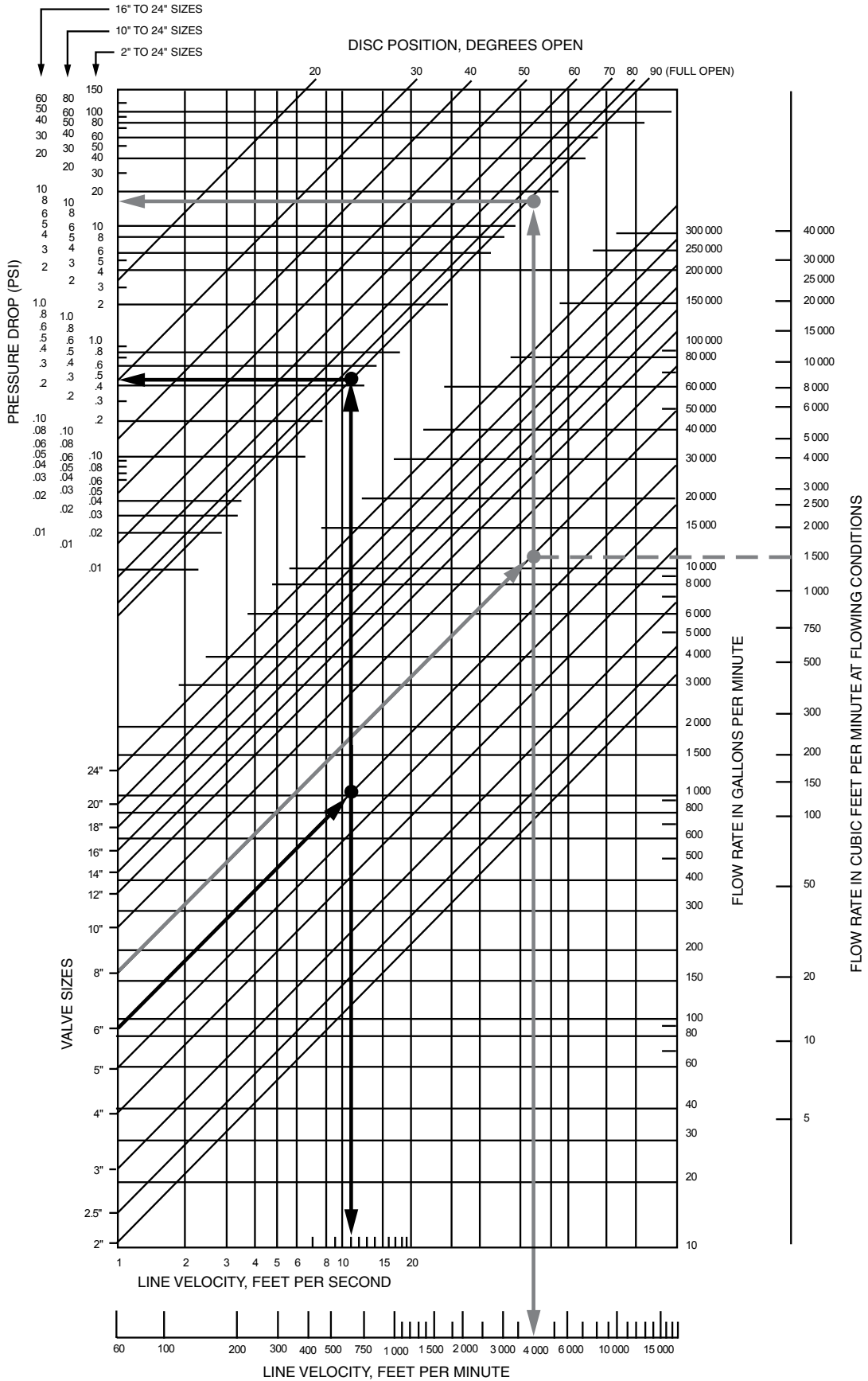

Technical Data

Seat Temperature Ratings and Application Information

Elastomer	Continuous Temp Range	Description
Buna-N	+10°F to 180°F	<p>Also known as Nitrile or NBR. Buna-N is a good, general purpose material for most general services such as water at ambient temperatures, vacuum, compressed air, salt solutions, alkaline solutions and aliphatic h hydrocarbons (saturated and unsaturated).</p> <p>Buna-N is not recommended for strong oxidizing agents, nitrated hydrocarbons, Ketones, acetates, phenols, aldehydes or for gasolines with additives. Also, Buna-N can swell in hot water applications, and increase operating torque.</p>
EPDM	-30°F to 275°F	<p>EPDM is a synthetic rubber suitable for many general purpose applications with higher temperature requirements. It is acceptable for hot and chilled water, glycols, detergents, phosphate esters, Ketones and alcohols.</p> <p>EPDM is not suitable for any hydrocarbon-based oils and lubricants, or in compressed air systems with hydrocarbons.</p>
Viton®	+10°F to 400°F	<p>Viton® is a fluoroelastomer with exceptional resistance to oils and chemicals at higher temperatures. Viton® is suitable for hydrocarbons, and has a greater chemical resistance than Buna-N. Viton® can also be recommended for mineral acids, dilute and concentrated solutions and alcohols.</p> <p>Viton® is not recommended for higher temperature water and steam applications as it has a tendency to swell. Also, Viton® hardens at the lower end of the temperature range, which can increase operation torque.</p>

Crane is please to offer other seat materials upon request. Please consult your sales representative or the factory for availability and application information.

Gear Operators Features and Dimensions

Gear operators can be used for on/off and throttling control of Center Line resilient seated butterfly valves. All models are weatherproof and usable for above ground service. Consult factory for buried service gears. For manual operation of valves, gear operators are required for valves 14" and larger and are recommended for valves 8" and larger.

Features

Gear operators from Center Line are 90° manual actuators, and they come with a handwheel, chainwheel, or square nut input device. The durable housing completely encloses the worm gear (on the input shaft) and the segment gear (on the output). Adjustable stops are standard and factory set when installed at the factory. Fully adjustable memory stops are available as an option. A position indicator is standard on all models for above ground service.



Specifications

Operation Handwheel or chainwheel or 2" square nut. Input shaft extension available.

Mounting Available with bolt patterns and bore/keyway for direct mount to all 2" through 30" Center Line resilient seated butterfly valves. Dual bolt patterns accommodate different pad designs. Gears are drilled for ISO pattern through 24". Contact factory for 30" and above.

Dimensions and Weights

Valve Size (Drawing 1)	A	A1	C	E	F	G	H	Ø1	J	ØK	M	D	P	Q	Ø	ØD2	ØE	Wt. (Kg.)
2-6 in.	12.56	9.52	10.72	2.52	1.46	2.36	6.00	0.76	1.36	0.24	1.66	3.68	3.36	7.06	12.00	6.08	1.52	27.1
50-150 mm	314.00	238.00	268.00	63.00	37.00	59.00	150.00	19.00	34.00	6.00	41.50	92.00	84.00	176.50	300.00	152.00	38.00	(12.3)
8-14 in.	12.28	9.04	10.60	3.12	1.54	2.74	5.12	0.76	1.36	0.24	1.53	5.60	3.36	7.90	12.00	6.48	1.52	31.7
200-350 mm	307.00	226.00	265.00	78.00	38.50	68.50	128.00	19.00	34.00	6.00	38.20	140.00	84.00	197.50	300.00	162.00	38.00	(14.4)
16-18 in.	16.28	11.08	13.76	4.80	1.60	4.08	5.60	1.00	1.36	0.32	2.28	7.88	5.00	11.60	18.00	10.40	2.00	77.4
400-450 mm	407.00	277.00	344.00	120.00	40.00	102.00	140.00	25.00	34.00	8.00	57.00	197.00	125.00	290.00	450.00	260.00	50.00	(35.2)

Valve Size (Drawing 2)	A	B	C	D	E	F	Ø	Ø1	Ø2	Wt. (Kg.)
20 in.	7.40	6.40	4.40	18.90	4.60	2.50	18.00	0.98	0.32	121.0
500 mm	185.00	160.00	110.00	473.00	115.00	63.00	450.00	25.00	8.00	(55.0)
24 in.	7.40	6.40	5.00	20.00	4.80	2.50	18.00	0.98	0.32	132.0
600 mm	185.00	160.00	125.00	500.00	120.00	63.00	450.00	25.00	8.00	(60.0)
28 in.	N/A	N/A	N/A	N/A	N/A	N/A	N/A	N/A	N/A	N/A
700 mm	N/A	N/A	N/A	N/A	N/A	N/A	N/A	N/A	N/A	N/A
30 in.	10.60	6.60	6.40	21.80	5.12	3.12	18.00	0.98	0.32	198.0
750 mm	265.00	165.00	160.00	545.00	128.00	78.00	450.00	25.00	8.00	(90.0)
32 in.	9.72	6.92	6.48	21.20	6.56	3.52	17.40	0.98	0.32	292.6
800 mm	243.00	173.00	162.00	530.00	164.00	88.00	435.00	25.00	8.00	(133.0)
36 in.	11.12	8.04	7.84	21.44	10.32	5.04	17.40	0.98	0.32	424.6
900 mm	278.00	201.00	196.00	611.00	258.00	126.00	435.00	25.00	8.00	(193.0)
40 in.	N/A	N/A	N/A	N/A	N/A	N/A	N/A	N/A	N/A	N/A
1000 mm	N/A	N/A	N/A	N/A	N/A	N/A	N/A	N/A	N/A	N/A
42 in.	16.72	10.20	9.60	25.56	12.40	5.04	17.40	0.98	0.32	792.0
1050 mm	418.00	255.00	240.00	611.00	310.00	126.00	435.00	25.00	8.00	(360.0)
48 in.	16.72	10.20	9.60	25.56	12.40	5.04	17.40	0.98	0.32	792.0
1200 mm	418.00	255.00	240.00	639.00	310.00	126.00	435.00	25.00	8.00	(360.0)

Some sizes Series 200 and 225/250 require different operators, please consult factory.

Gear Operators Dimensions

Drawing 1 (for sizes 2" - 18")

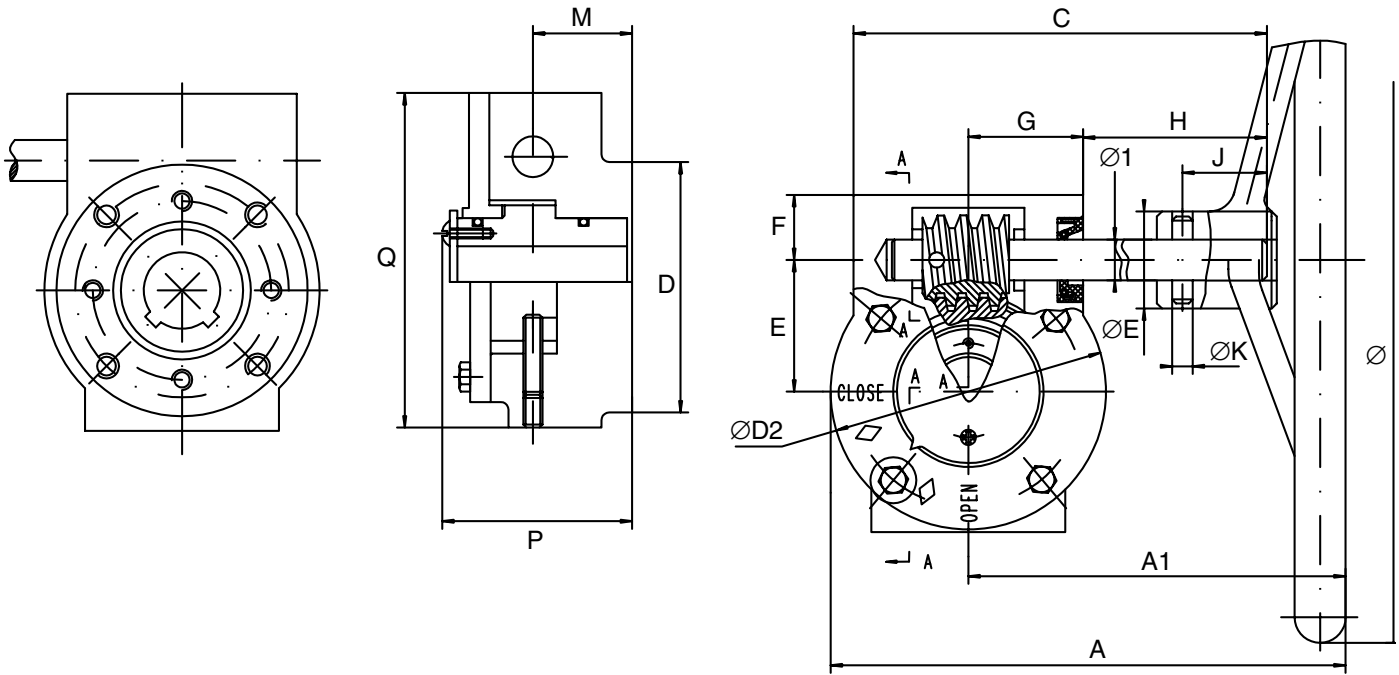

Drawing 2 (for sizes 20" and larger)

