

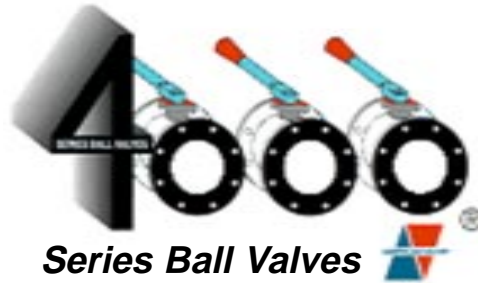

P.O. Box 35229  
Greensboro, NC 27425  
1-800-635-0101  
or (336) 668-0554  
fax: 1-800-876-0109  
or (336) 668-4070

sales@americanvalve.com  
<http://www.americanvalve.com>

## Installation, Maintenance & Operation Guide



This document contains information pertaining to American Valve models 4000, 4000D, and 4001. American Valve reserves the right to change design features from time to time. Diagrams and descriptions in this guide may not exactly match your particular valve. If you are unsure of or do not completely understand a particular procedure, please consult the factory.

### \*\*\*WARNING\*\*\*

For your personal safety and protection, it is important that you observe the following precautions before removing the valve from service or disassembling the valve.

1. Keep hands and fingers out of the valve. Actuated valves may close without warning, resulting in serious injury.
2. It is possible that residual media or pressure may be trapped inside the valve cavity. Ensure that the line and valve are properly depressurized and be aware of any residual harmful substances that may still be present.
3. To depressurize the valve:
  - A. Repeatedly open and close the valve to both drain the line and relieve any residual pressure in the valve cavity. Leave the valve in the open position.
  - B. Repeat this procedure once the valve is removed from the line and standing in the vertical position.
4. Exercise caution when handling a valve that has been used to control hazardous media. It is recommended that the valve and line be thoroughly flushed prior to removal and/or disassembly. Cycle the valve slowly while flushing to clear the cavity.

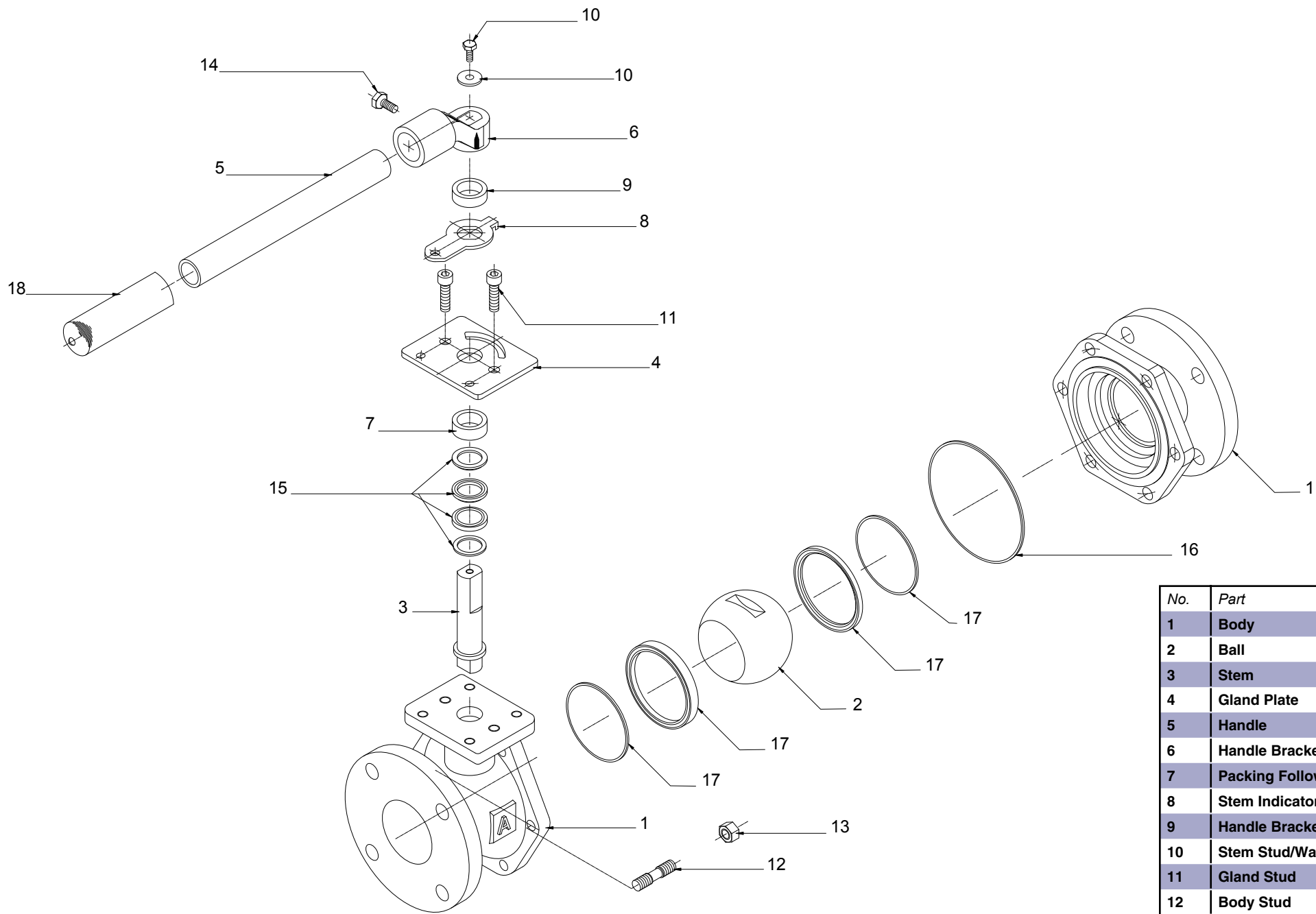

No.	Part
1	Body
2	Ball
3	Stem
4	Gland Plate
5	Handle
6	Handle Bracket
7	Packing Follower
8	Stem Indicator
9	Handle Bracket Spacer
10	Stem Stud/Washer
11	Gland Stud
12	Body Stud
13	Body Nut
14	Handle Bracket Bolt
15	Packing
16	Body Gasket
17	Seat Ring
18	Handle Grip



## 1. Installation

1. Prior to installation, all valves and mating flanges should be inspected to ensure gasket surfaces are free from defects.
2. The valve and line should be free from dirt and debris, which can damage valve seats.
3. Piping should be checked for proper alignment and appropriate supports. Valves should never be used to align or brace improperly positioned pipe.
4. Our 4000 Series can be installed for flow in either direction. Visually inspect valve for foreign matter.
5. Install valve into pipeline and tighten bolts evenly according to recommendations of gasket manufacturer.
6. DO NOT TIGHTEN OR OTHERWISE ADJUST BODY BOLTS. THEY ARE ATA PRE-SET EVENLY DISTRIBUTED TORQUE. OVERTIGHTENING OF ONE SIDE MAY CAUSE LEAKAGE, AND NECESSITATE BODY SEAL REPLACEMENT.

## 2. Operation

1. The operation of 4000 Series ball valves consists of rotating the handle 90° (1/4 turn) counter-clockwise to open.
2. When the valve is in the open position, the handle is parallel to the pipeline.
3. When the valve is in the closed position, the handle is perpendicular to the pipeline.
4. Media which can solidify, crystallize, or polymerize should not be allowed to stand in ball valve cavities.

## 3. General Maintenance

1. Any disassembly of the valve body requires that the body gasket be replaced. We strongly recommend replacing the seats as well.
2. Body bolts are tightened to pre-set torques evenly distributed around the body. Any tightening or loosening of these bolts may result in leakage through the body gasket. Should this occur, replace the gasket and consult the factory for recommended torque settings and assembly procedures.
3. No special tools are needed for maintenance of American Valve 4000 Series Ball Valves.

## 4. Troubleshooting

1. Manually operated valves from time to time require tightening of the two allen bolts on top of the gland plate. This will compress the packing and ensure a tight stem seal. If this does not solve the problem, then the stem packing may need to be replaced.
2. In-line leakage of actuated valves is usually caused by a faulty limit switch or setting. Actuators can be out of alignment, not allowing the valve to close completely. Debris may also cut the seating surfaces, allowing a leak path to develop.
3. Complete repair kits are available, and include replacement seats, body seal, and packing set. When ordering, please note what model 4000 you have (Cast Iron is painted black, Ductile Iron is painted gray, and Stainless Steel is unpainted). Other replacement parts are available on request.

## 5. Procedure for Converting Handle Operated Valve to Gear Operated (2 1/2" - 4")

- A. Items to remove to prepare valve for gear operator:
  1. Handle Bracket and assembly (discard)
  2. Retaining Ring (discard)
  3. Spring (discard)
  4. Indicator (discard)
  5. (2) Allen screws (save)
  6. Gland plate (save)
  7. Leave packing collar on valve.
- B. Kit needed to install gear operator includes:
  1. Gear Operator
  2. Gear Operator adapter bracket (tubular steel drilled on both ends)
  3. Gear Operator stem adapter
  4. (8) Bolts
  5. (8) Lock-washers
  6. Collar
- C. Procedures for mounting gear operator:
  1. Place adapter bracket (item B-2) onto top of valve, aligning six (6) holes. Insert (4) bolts with washer into outside holes and tighten.
  2. Place collar (item B-6) over stem, slide down onto packing collar (item A-7).
  3. Slide gland plate (item A-6) over stem, slide down to sit on collar.
  4. Screw (2) Allen screws (item A-5) through gland plate and adapter bracket, tighten into top of valve.
  5. Place stem adapter (item B-3) onto stem.
  6. Place gear operator (align with square on stem adapter)  
-Handle should end up to side of valve.



## 6. Procedure for Converting Handle Operated Valve to Gear Operated (6" - 10")

- A. Items to remove to prepare valve for gear operator:
1. Handle Bracket and assembly (discard)
  2. Retaining Ring (discard)
  3. Collar (save)
  4. Indicator (discard)
  5. (2) Allen screws (save)
  6. Gland plate (save)
  7. Leave packing collar on valve.
- B. Kit needed to install gear operator includes:
1. Gear Operator
  2. Gear Operator adapter bracket (tubular steel drilled on both ends)
  3. Gear Operator stem adapter
  4. (8) Bolts
  5. (8) Lock-washers
- C. Procedures for mounting gear operator:
1. Place adapter bracket (item B-2) onto top of valve, aligning six (6) holes. Insert (4) bolts with washer into outside holes and tighten.
  2. Place collar (item B-6) over stem, slide down onto packing collar (item A-7).
  3. Slide gland plate (item A-6) over stem, slide down to sit on collar.
  4. Screw (2) Allen screws (item A-5) through gland plate and adapter bracket, tighten into top of valve.
  5. Place stem adapter (item B-3) onto stem.
  6. Place gear operator (align with square on stem adapter)
    - Handle should end up to side of valve.
    - Arrow on top of gear operator should indicate open or closed position of valve.
    - Lower gear operator onto valve.
  7. Insert (4) bolts with washer through gear adapter into gear operator and tighten.
  8. Turn valve to each open and closed position and set adjustment screws (2) on side of gear operator. Protect with black plastic cap.