

Class 150 • Outside Screw & Yoke • Bolted Bonnet

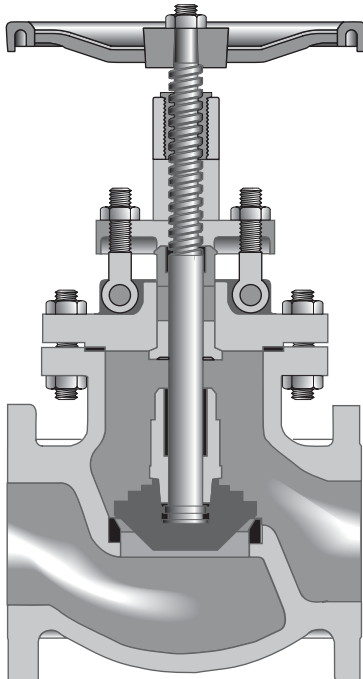

Figure 143
Flanged
Figure 143½
Butt Weld

Size Range:
2 through 14 inches

Pressure Temperature Rating
Carbon Steel
ASTM A216 Grade WCB
285 psi @ -20°F to 100°F

Material of Construction

Description	Material
Body	WCB
Bonnet	WCB
Seat Rings	Hardfaced
Disc	13% CR Overlay
Stem	410 SS
Packing	Graphite
Bonnet Gasket	SS Tanged Ref. Flex. Graphite
Back Seat	410 SS
Disc Stem Nut	410 SS
Disc Washer	Carbon Steel
Gland	410 SS
Gland Flange	WCB
Eye Bolt	Steel
Eye Bolt Nuts	A563 Gr. A or O
Pins	-
Bonnet Studs	A193 Gr. B7
Bonnet Nuts	A194 Gr. 2H
Handwheel	WCB
Handwheel Nut	A194 Gr. 2H
I.D. Tags	SS
I.D. Pins	SS

Industry Standards

Steel Valves	ASME B16.34
Face-to-Face/End-to-End	ASME B16.10
Flange Dimensions	ASME B16.5
Weld End	ASME B.16.25
Testing	API 598
Acceptance	API RP591

Dimensions and Weights

Valve Size	Weight (pounds)		Dimensions (inches)		
			A	B Valve Open	C
2	53	43	8.00	15.00	8.00
2½	70	60	8.50	17.12	8.00
3	90	73	9.50	18.50	10.00
4	143	112	11.50	21.00	12.00
5	199	165	14.00	23.00	12.00
6	246	195	16.00	25.50	16.00
8	392	330	19.50	30.00	16.00
10	605	480	24.50	34.00	20.00
12	900	820	27.50	39.50	20.00
14	1000	880	31.00	41.38	24.00

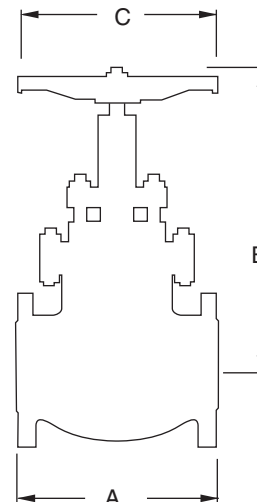

Materials of Construction

Steel bolted bonnet valves described in this catalog are typically manufactured of carbon steel. When specified, the valves are available in the alloys shown below which are suitable for steam, water, oil, oil vapor, gas and general services. Please contact factory or customer service for availability and material breakdowns.

Body and Bonnet or Cap Materials

Part No. Suffix	ASTM Classification	Material Classification	Service Conditions
None	A216 WCB	Carbon Steel	For service up to 1000° F where corrosion and oxidation are not a factor. (1) (4) (5)
6	A217 WC6	1 ¼ CR, ½ Mo	For service up to 1000° F. (3) (4) (5)
9	A217 WC9	2 ¼ CR, 1 Mo	For service up to 1100° F where good creep strength is required. (3) (4) (5)
5	A217 C5	5% CR, ½ Mo	For service up to 1200° F. Best corrosion and oxidation resistance plus high creep strength are required.
12	A217 C12	9% CR, 1 Mo	For service up to 1200° F. Best corrosion and oxidation resistance than other grades.
2	A351 LCC	Low Carbon Steel	For service from -50° F to 650° F. This material must be quenched and tempered to obtain tensile and impact properties needed at sub-zero temperatures.

(1) Upon prolonged exposure to temperatures above 800° F, the carbide phase of carbon steel may be converted to graphite. Permissible, but not recommended for prolonged usage above 800° F.

(2) Valve regularly rated to 1000° F.

(3) Considerations should be given to the possibility of excessive oxidation (scaling) when used above 1050° F.

(4) Product used within the jurisdiction of Section 1 Power Boilers of the ASME Boiler and Pressure Vessel code is subject to the same temperature limitations as specified in that document.

(5) Product used within the jurisdiction of Power Piping, ASME Code for Pressure Piping B31.1, is subject to the same maximum temperature limitations placed upon the material in paragraph 124.2.

Trim Material

Part No. Suffix	API Trim Number	Nominal Trim	Seating Surfaces	Stem Material	Temperature
X	1	F6 / F6 (1)	13 Cr ASTM A217 (CA15)	13 Cr (410)	1100° F
UF*	5	HF / HF (2)	Stellite 6	13 Cr (410)	1200° F
A	9	Monel / Monel (4)	Monel	Monel	450° F
L	10	316 / 316 (3)	316 SS	316 SS	850° F
XUF*	8	F6 / HF (1) (2)	13 Cr ASTM A217 (CA 215) Stellite 6	13 Cr (410)	1100° F
AUF*	11	Monel / HF (4) (2)	Monel Stellite 6	Monel	450° F
LUF*	12	316 / HF (3) (2)	316 SS Stellite 6	316 SS	850° F

(1) 13% Chromium AISI Type 410 Stainless Steel.

(2) Hard Facing is weld deposited Cobalt base alloy.

(3) Austenitic Stainless Steel is a Ni-Cr-Mo stainless steel in the AISI Type 316 category.

(4) Ni-Cu Alloy.

*F denotes Flex Wedge (only applies to Gate Valves).

Valve Modification Suffix Identification

S.I.	Description	S.I.	Description	S.I.	Description	S.I.	Description
TD	Drain, Drill, and Tap	ST	Special Trim	SP	Special Paint	OV	(1) Gear (4) Pneumatic
BP	Bypass	BW	Special Butt-Weld End Prep	LD	Locking Device		(2) Chainwheel (5) Hydraulic
PG	Special Packing and/or Gasket	RJ	Ring Joint	LR	Lantern Ring		(3) Electric (6) Other

Typical Globe Valve Features

Crane globe valves are highly efficient for services requiring frequent operation and throttling when pressure drop across the valve is about 20% of inlet pressure. Closer throttling, creating higher pressure drops may cause cavitation or excessive velocities which could cause high noise levels, vibration and possible damage to the valve or adjacent piping. Globe valves can be equipped with optional operators and are available with a variety of trims to match service requirements.

1. **Body:** Body is cast with heavy sections reinforced at points subjected to the greatest stress. Valves are available in both flanged and butt welding ends. All conform to ASME specifications.
2. **Bonnet**
3. **Seat Ring**
4. **Disc**
5. **Disc Stem Nut:** Disc Stem Ring connects the disc to the stem, permitting the disc to swivel and aid in securing tight seating for trouble-free service.
6. **Disc Washer**
7. **Stem:** Stem has long engagement with yoke bushing for accurate seating.
8. **Bonnet Bushing**
9. **Yoke Bushing**
10. **Wheel Nut**
11. **Packing**
12. **Gland:** Gland is a two-piece, ball-type which exerts even pressure on the packing without binding the stem.
13. **Gland Flange**
14. **Gland Eye Bolts:** Eye bolts are securely fastened to the bonnet yet swing away to permit easy access to the stuffing box.
15. **Bonnet Gasket:** Bonnet gasket provides a positive seal against leakage. Class 150 and 300 valves have a male/female bonnet joint. A ring-type gasket is employed in Class 600.
16. **Bonnet Studs**
17. **Bonnet Nuts**
18. **Pin**
19. **Handwheel**

