

TITAN

WYE STRAINER • SOCKET WELD & THREADED

Class 600 • Carbon and Stainless Steel



Size Range: 1/4" thru 3"

Models-Threaded:

YS 81-CS (Carbon Steel)

YS 81-SS (Stainless Steel)

Models-Socket Weld:

YS 82-CS (Carbon Steel)

YS 82-SS (Stainless Steel)

WORKING PRESSURES & TEMPERATURE - NON-SHOCK

ANSI 600 lb Class	YS 81/82-CS	YS 81/82-SS
WOG (Water, Oil, Gas)	1480 PSI @ 100 °F	1440 PSI @ 100 °F
Saturated Steam	600 PSI @ 489 °F	600 PSI @ 489 °F
MAX Liquid	825 PSI @ 800 °F	700 PSI @ 1000 °F

Features:

- Self Cleaning Type
- Easily Removable Screen Caps
- Hex Ends For Easy Installation
- Straight Threads On Cap Allows For Easy Removable Prior To Cleaning
Also Helps To Ensure Proper Alignment Of Screen During Reassemble
- Precision Machined Seat
- Tapped NPT Blow-off
- Drain/Blow-off Connection Furnished With Plug - Standard
- Blow-Down Operations Can Easily Be Accomplished By Replacing the Plug With A Titan FCI Blow-Down Ball Valve
- Large Open Area - Minimum 2.5x Larger Than Corresponding Pipe Size
- Carbon Steel Bodies Are Epoxy Painted
- Investment Casting (Body/Cap) Provides Unmatched Dimensional Accuracy

Heavy Duty, Rugged Design - Ideal For High Pressure Applications



TITAN FLOW CONTROL
LUMBERTON, NC USA

WYE STRAINER

THREADED ENDS

YS 81-CS (Carbon)

YS 81-SS (Stainless)

SOCKET WELD ENDS

YS 82-CS (Carbon)

YS 82-SS (Stainless)

ANSI Class 600 lb

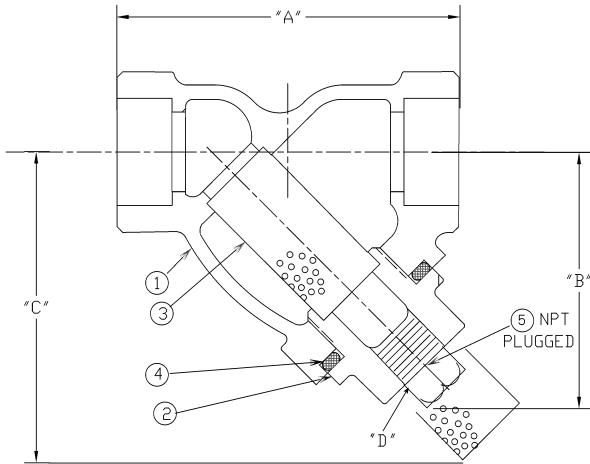

BILL OF MATERIALS

No.	PART	YS 81-SS & YS 82-SS	YS 81-CS & YS 82-CS
1	BODY	ASTM A351 CF8M 316	ASTM A216 WCB
2	CAP	ASTM A351 CF8M 316	ASTM A216 WCB
3	SCREEN*	304 SS	304 SS
4	GASKET*	SPIRAL WOUND STAINLESS NON-ASBESTOS	
5	PLUG	316 SS	CARBON STEEL

*Recommended spare parts

Notes:

- Strainers are also available in many optional materials such as LCB, WC6, WC9, 316L, Alloy 20, and Monel.
- Threaded End ASME/ANSI B1.20.1 & B16.11
Socket Weld End ASME/ANSI B16.11
- Bolted cover design on 2 1/2"-3" sizes.
2 1/2" ~ 3" are ANSI Class 1500

DIMENSIONS:

SIZE	in	1/4	3/8	1/2	3/4	1	1 1/4	1 1/2	2	2 1/2	3
	mm	8	10	15	20	25	32	40	50	65	80
A DIMENSION FACE TO FACE	in	2.93	2.93	2.93	3.68	4.56	4.93	5.56	6.93	12.00	12.00
	mm	75	75	75	94	116	126	142	177	305	305
B DIMENSION CTR. LINE TO BOTTOM	in	2.37	2.37	2.37	2.81	3.68	4.12	4.75	6.00	10.50	10.50
	mm	61	61	61	72	94	105	121	153	267	267
C DIMENSION SCREEN REMOVAL	in	2.62	2.62	2.62	3.37	4.75	5.25	6.00	7.25	16.00	16.00
	mm	67	67	67	86	121	134	153	184	407	407
D DIMENSION NPT BLOW-OFF	in	1/4	1/4	1/4	3/8	3/8	3/4	3/4	1	C/F	C/F
	mm	8	8	8	10	10	20	20	25	C/F	C/F
ASSEMBLED WEIGHT	lb	1.5	1.5	1.5	2.5	5.0	5.5	9.0	13.0	96.0	92.0
	kg	0.7	0.7	0.7	1.1	2.3	2.5	4.1	5.9	43.5	41.7
Flow Coefficient	C _v	7	7	9.4	18	30	45	63	98	130	180

*Dimensions (inches) are rounded down to two decimal places.

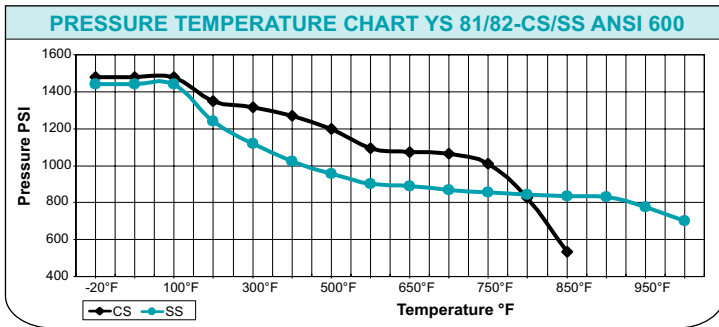

- CS not recommended for prolonged use above 800 °F
- SS not recommended for prolonged use above 1000 °F

TESTING:

Strainers are individually, hydrostatically tested at 1.5 x the 100 °F rating, rounded off to the next higher 25 PSI measurement .

WORKING PRESSURES & TEMPERATURE - NON-SHOCK

ANSI 600 lb Class	YS 81/82-CS	YS 81/82-SS
WOG (Water, Oil, Gas)	1480 PSI @ 100 °F	1440 PSI @ 100 °F
Saturated Steam	600 PSI @ 489 °F	600 PSI @ 489 °F
Max Liquid	825 PSI @ 800 °F	700 PSI @ 1000 °F

STANDARD SCREEN SELECTIONS

Sizes	Water Service	Open Area	Steam	Open Area
1/2"-3"	0.062 (1/16)	37 %	0.033 (1/32)	28 %

A wide range of optional wire mesh and perforated screens are available.

APPLICABLE STANDARDS

Design	B1.20.1 & B16.11
Shell Wall Thickness	B16.11
Pressure vs. Temp. Rating	B16.34

Ordering Code: _____ Size: _____
 Customer/Project: _____
 Inq./P.O. No.: _____
 Titan Order No.: _____
 Certified By: _____ Date: _____



TITAN FLOW CONTROL, INC.
Engineering Specification Submittal

WYE STRAINER - YS 81/82-CS/SS

Series	Size	Part No.	Material Trim Code	Drawing No.
				YS 81/82-CS/SS