

TECHNOCHECK STYLE 5103 GROOVED ENDS

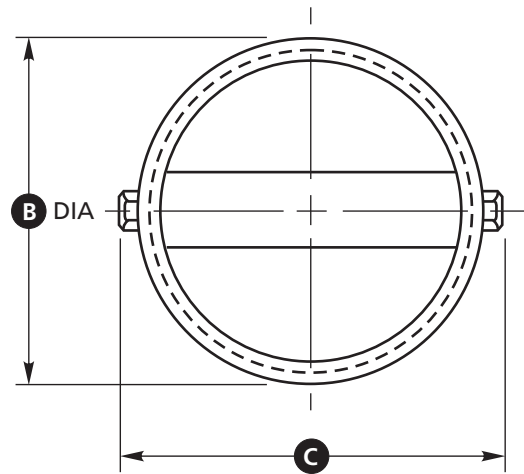
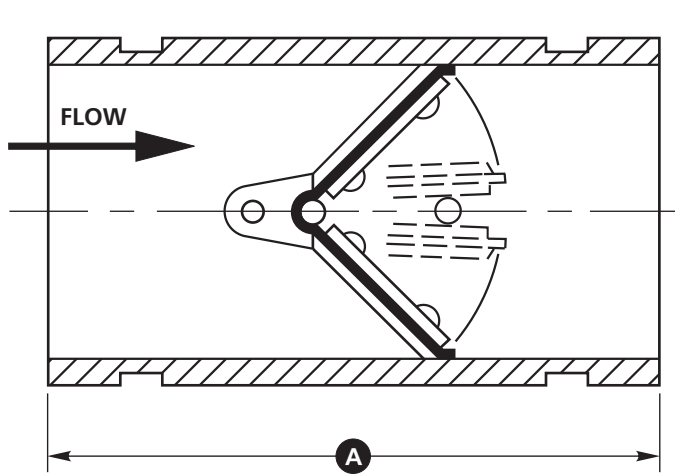

GENERAL DIMENSIONS FOR STYLE 5103

Valve Size inches	A	B	C
1	5 3/4	1.315	1 5/8
1 1/4	5 3/4	1.660	2
1 1/2	5 3/4	1.900	2 1/4
2	5 3/4	2 3/8	2 3/4
2 1/2	5 3/4	2 7/8	3 1/4
3	5 3/4	3 1/2	3 7/8
4	6 3/4	4 1/2	4 7/8
5	7 3/4	5 9/16	6 1/8
6	8 3/4	6 5/8	7 1/8
8	10 3/4	8 5/8	9 1/2
10	12 3/4	10 3/4	11 1/2
12	14 3/4	12 3/4	13 3/4
14	16 3/4	14	15
16	18 3/4	16	17
18	20 3/4	18	19
20	22 3/4	20	21 1/4

All Dimensions in inches.

STANDARD MODELS & MATERIALS

Style	Body	Internal	Cold Working Pressure (psig)
5103-AL-V	Aluminum	Aluminum	50
5103-V	Steel	Aluminum	150
5103-316-V	316 Stainless Steel	316 Stainless Steel	150
Standard Elastomer: Buna-N			

Combination End Configurations also Available. Consult Factory for Materials, Sizes and Pressure Ratings not shown.

OPTIONAL MATERIAL SELECTION

Internal Materials

- Aluminum
- Brass
- 316 Stainless Steel
- Plated Steel

Sealing Member Materials

Material	Temperature Range*
• Buna-N	-60°F to 225°F
• Neoprene	-40°F to 225°F
• EPDM	-40°F to 300°F
• Viton	-20°F to 400°F
• Silicone	-100°F to 500°F

* This temperature range is for general guidance. The figures may vary with application.

Spring Material

- 302 Stainless Steel

TECHNOCHECK STYLE 5103 GROOVED ENDS

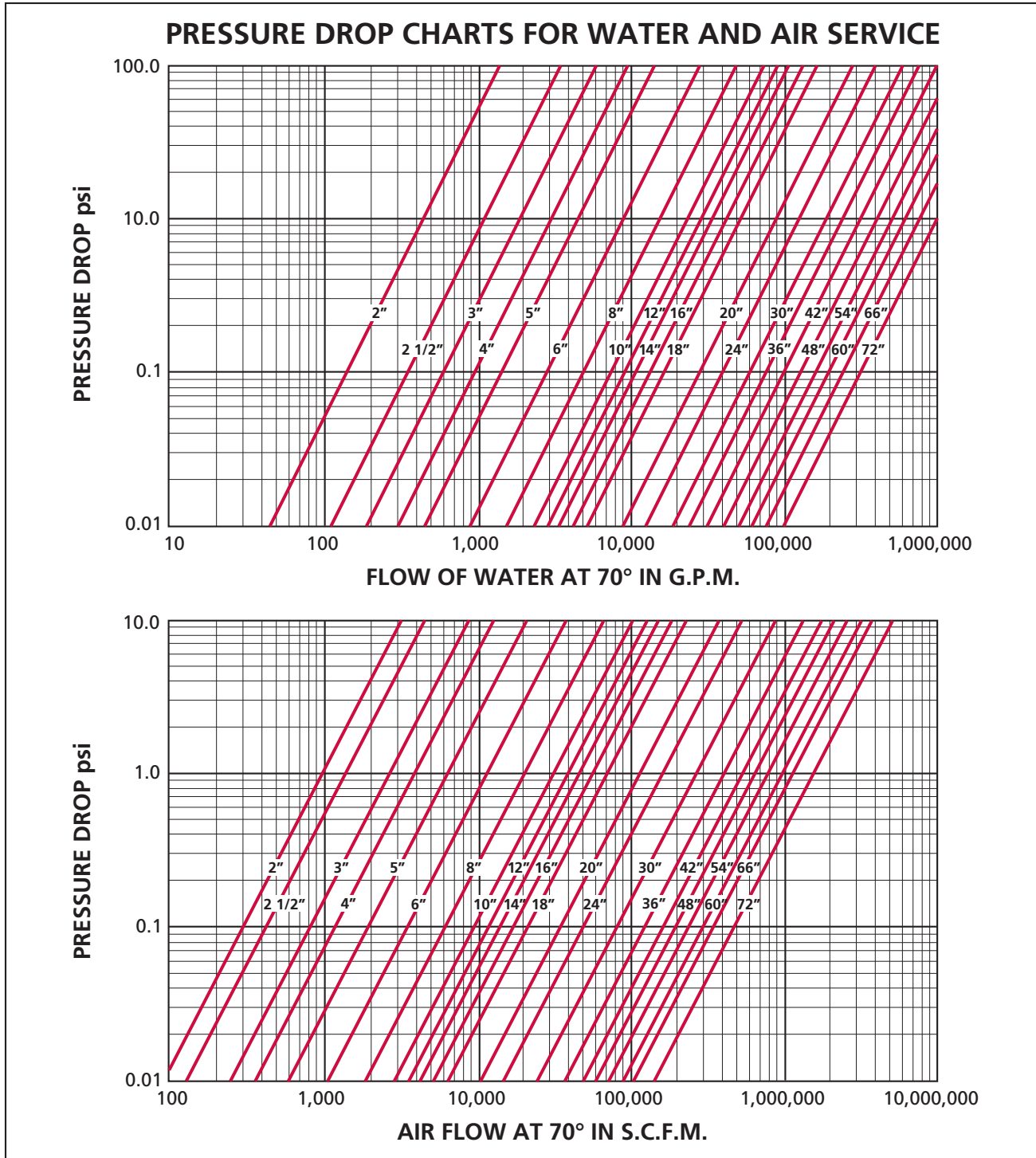

VALVES & MEASUREMENT
 3250 Briarpark Drive, Suite 300
 Houston, Texas 77042
 USA Toll Free 800 323 9160

For the most current contact and location information go to: www.c-a-m.com/valvesandmeasurement