

## TECHNOCHECK STYLE 5002 MALE THREADED ENDS

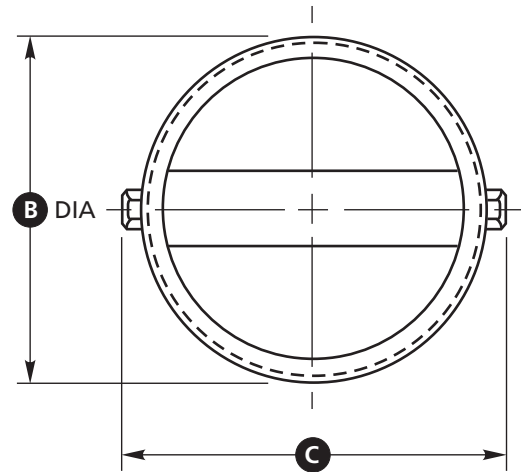
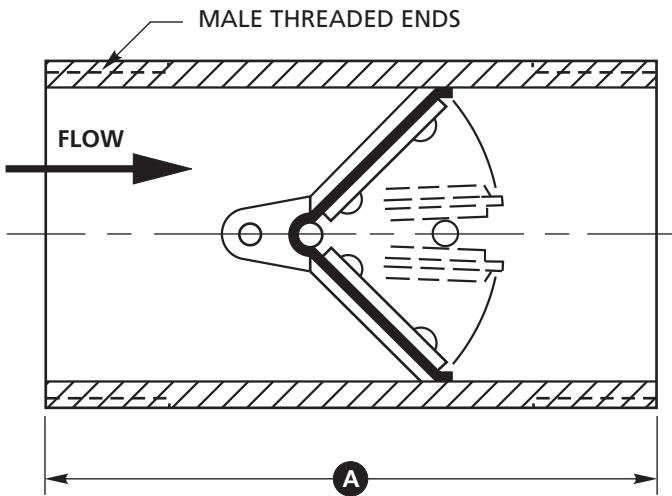

### GENERAL DIMENSIONS FOR STYLE 5002

Valve Size inches	A	B	C
1	3 1/2	1.315	1 5/8
1 1/4	3 1/2	1.660	2
1 1/2	4	1.900	2 1/4
2	4	2 3/8	2 3/4
2 1/2	5	2 7/8	3 1/4
3	5 1/2	3 1/2	3 7/8
4	6	4 1/2	4 7/8
5	7	5 9/16	6 1/8
6	8	6 5/8	7 1/8
8	10	8 5/8	9 1/2
10	12	10 3/4	11 1/2
12	14	12 3/4	13 3/4

All Dimensions in inches.

### STANDARD MODELS & MATERIALS

Style	Body	Internal	Cold Working Pressure (psig)
5002-AL	Aluminum	Aluminum	50
5002-BR	Brass	Brass	150
5002-316	316 Stainless Steel	316 Stainless Steel	150
5002 Class A	Steel	Aluminum	150
5002 Class D	Steel	Plated Steel	150
Standard Elastomer: Buna-N			

Combination End Configurations also Available. Consult Factory for Materials, Sizes and Pressure Ratings not shown.

### OPTIONAL MATERIAL SELECTION

#### Internal Materials

- Aluminum
- Brass
- 316 Stainless Steel
- Plated Steel

#### Sealing Member Materials

Material	Temperature Range*
• Buna-N	-60°F to 225°F
• Neoprene	-40°F to 225°F
• EPDM	-40°F to 300°F
• Viton	-20°F to 400°F
• Silicone	-100°F to 500°F

\* This temperature range is for general guidance. The figures may vary with application.

#### Spring Material

- 302 Stainless Steel

TECHNOCHECK STYLE 5002 MALE THREADED ENDS

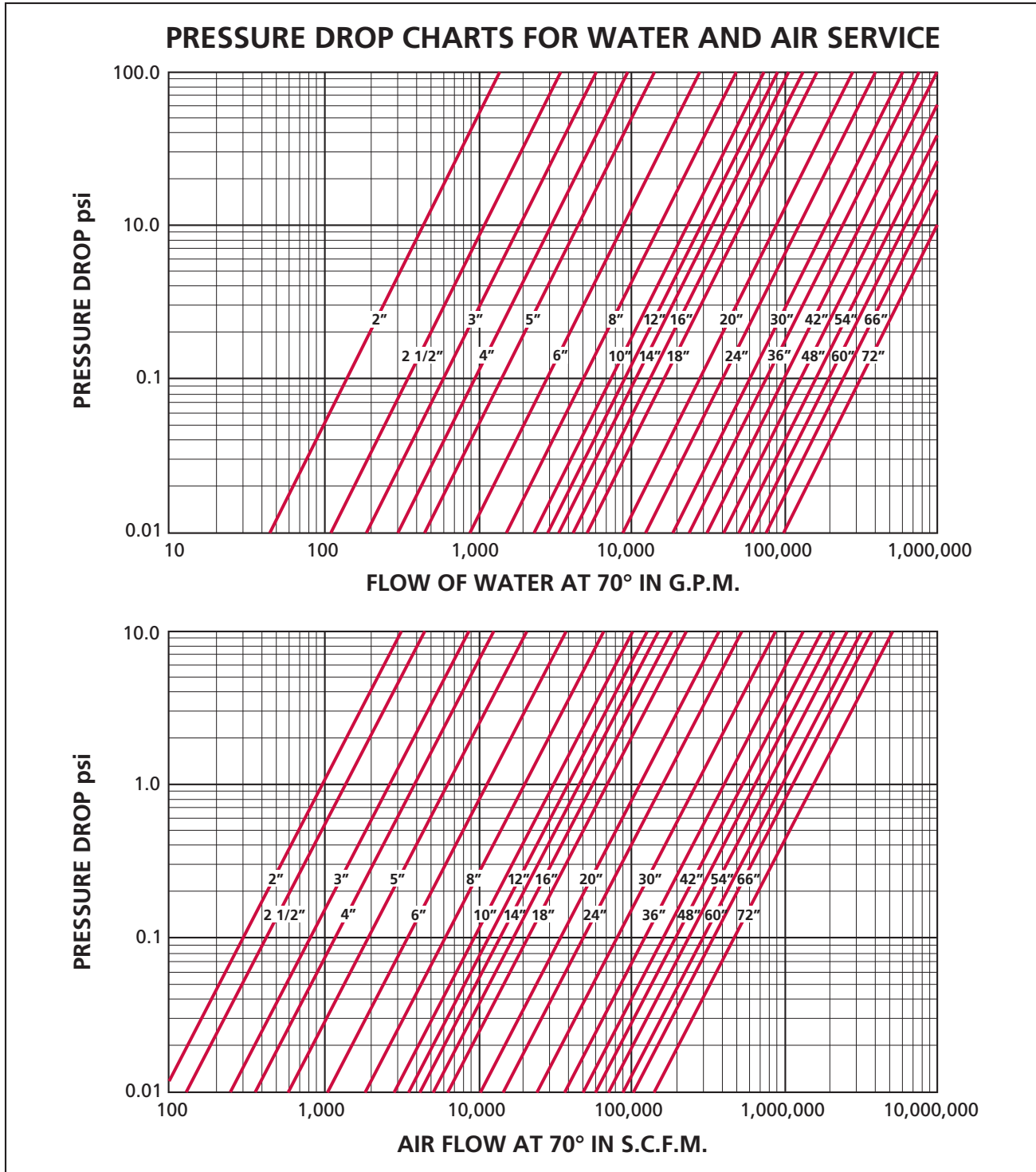

**VALVES & MEASUREMENT**  
 3250 Briarpark Drive, Suite 300  
 Houston, Texas 77042  
 USA Toll Free 800 323 9160

For the most current contact and location information go to: [www.c-a-m.com/valvesandmeasurement](http://www.c-a-m.com/valvesandmeasurement)