



1040 N. Meridian Rd., P.O. Box 1556, Youngstown, Ohio 44501
 Phone: (330) 799-3333 Toll Free: 1-800-677-1799 FAX: (330) 797-3215

www.trumbull-mfg.com

ADJUSTABLE CHAINWHEELS

Ductile Iron
To Operate Overhead Valves From The Floor.

Ductile Iron Chainwheels allow operation of valves in high, hard-to reach locations by means of a slight pull on the sprocket chain. Universal design allows Chainwheel to be clamped to handwheel, or pinned directly to valve stem.

All Chainwheels are furnished with plated steel attachment hardware for clamping to handwheel. When Chainwheel is to be pinned to valve stem, a ductile iron bushing will be provided which can be machined to suit valve stem dimensions. Bushing and Chainwheel will be pre-drilled with pin hole, and supplied with a stainless steel pin for customer mounting to valve stem. Drilling of valve stem by customer. See reverse side for illustration of bushing.

SPECIFICATIONS:

Trumbull Item No. for Chainwheel	Size No.	Diameter of Chainwheel	Boxed Weight	O.D. Range of Handwheels Chainwheel Will Fit	Trumbull Item No. for Galv. Chain	Chain Weight per 100'	Length of Chain Required (2x Drop)
367-1873	TR-0.0	4"	3.0#	2" to 4"	172-1650	10.0#	Plus 1 ft.
367-1874	TR-1.0	6"	5.0#	4-1/4" to 5-3/4"	367-1894	17.5#	Plus 1 ft.
367-1875	TR-1.5	7-1/2"	9.2#	6" to 7-1/2"	367-1894	17.5#	Plus 1 ft.
367-1876	TR-2.0	9"	12.9#	7-3/4" to 9"	367-1894	17.5#	Plus 1-1/2 ft.
367-1877	TR-2.5	12-1/2"	15.7#	9-1/4" to 12-1/2"	367-1895	30.0#	Plus 1-1/2 ft.
367-1878	TR-3.0	15-1/2"	22.0#	12-3/4" to 15-1/2"	367-1895	30.0#	Plus 2 ft.
367-1879	TR-3.5	19"	31.5#	15-3/4" to 19"	367-1895	30.0#	Plus 2-1/2 ft.
367-1880	TR-4.0	22"	41.7#	19-1/4" to 22"	367-1896	35.0#	Plus 3 ft.
367-1881	TR-4.5	26"	48.6#	22-1/2" to 26"	367-1896	35.0#	Plus 3-1/2 ft.
367-1882	TR-5.0	30"	61.0#	22-1/2" to 36"	367-1896	35.0#	Plus 4 ft.

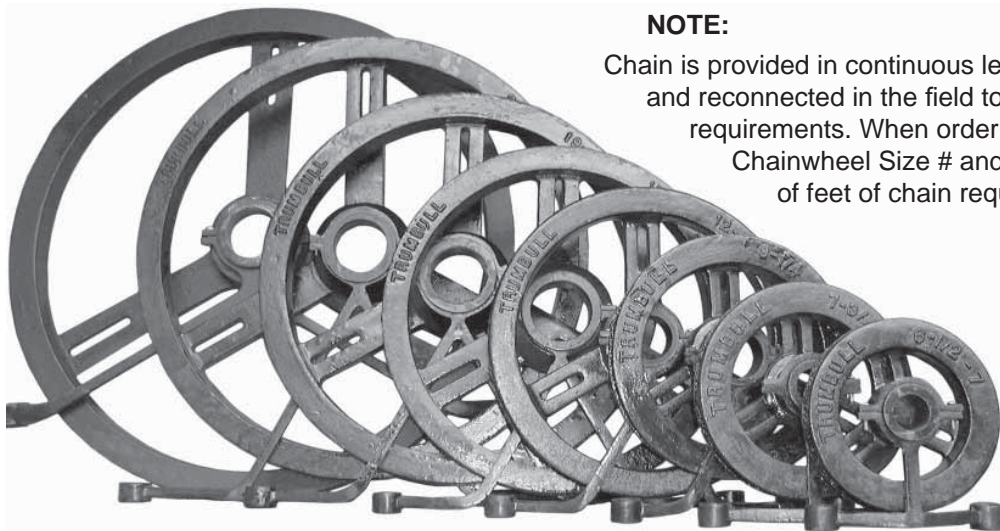

NOTE:

Chain is provided in continuous lengths. Easily cut and reconnected in the field to suit exact job requirements. When ordering, give the Chainwheel Size # and the number of feet of chain required.

NOTE: Also available in Type 316 Stainless Steel.

Adjustable Chainwheel with Chain Guide operates overhead valves from the floor.



DIMENSIONS:

Chainwheel Size	TR-0.0	TR-1.0	TR-1.5	TR-2.0	TR-2.5	TR-3.0	TR-3.5	TR-4.0	TR-4.5	TR-5.0
Item#	367-1873	367-1874	367-1875	367-1876	367-1877	367-1878	367-1879	367-1880	367-1881	367-1882
Chainwheel Assembly Fits Handwheel O.D. Range	2" to 4"	4-1/4" to 5-3/4"	6" to 7-1/2"	7-3/4" to 9"	9-1/4" to 12-1/2"	12-3/4" to 15-1/2"	15-3/4" to 19"	19-1/4" to 22"	22-1/2" to 26"	22-1/2" to 36"
Chain Size	Size #2	Size 1/0			Size 4/0			Size 5/0		
Chain Item#	172-1650	367-1894			367-1895			367-1896		
Attachment Set Size	CD*	CD**	A		B	C				D
Boxed Weight	1.8 lbs.	4.2 lbs.	9.2 lbs.	12.9 lbs.	15.7 lbs.	22.0 lbs.	31.5 lbs.	41.7 lbs.	48.6 lbs.	61.0 lbs.
Bushing Size	none		Small		Medium		Large			
Bushing Bore, Min.	n.a.		5/8"		15/16"		15/16"			
Bushing Bore, Max.	n.a.		1-1/4"		1-7/8"		2-3/4"			
A - Overall Height w/Guide	5"	6-7/8"	8-3/4"	10-3/4"	12-5/8"	16"	19"	23"	27"	30"
B - Overall Width	4-1/4"	5-3/4"	8-9/32"	9-17/32"	11-5/16"	15-15/32"	18-7/16"	22-19/32"	26-1/2"	30"
C - Overall Depth	1-7/8"	2-3/8"	2-1/2"	2-1/2"	2-9/16"	2-9/16"	2-9/16"	2-5/8"	2-5/8"	3-5/16"
D - Slot Width in Arms	3/16"	3/8"	5/16"	5/16"	5/16"	7/16"	7/16"	7/16"	7/16"	9/16"
E - Inner Bolt Circle Diam.	1-1/2"	2-3/8"	3-1/8"	3-3/8"	3-3/4"	7-1/2"	9-13/16"	12-9/16"	16-7/8"	16-1/16"
F - Outer Bolt Circle Diam.	2"	3-7/16"	4-7/8"	5-15/16"	7-11/16"	11"	14-13/16"	17-9/16"	22-3/8"	25-11/16"
G - Hub Bore Diam.	7/16"	13/16"	1-1/2"	1-1/2"	2-1/8"	2-1/8"	3"	3"	3"	3"
H - Hub Recess Diam.	3/4"	1-7/16"	----	2-3/4"	3"	3-1/2"	5"	5"	5"	5"
I - Hub Recess Depth	3/4"	1-3/8"	----	3/8"	9/16"	9/16"	13/16"	7/8"	7/8"	1-1/2"

* Clamp Disk 0

** Clamp Disk 1

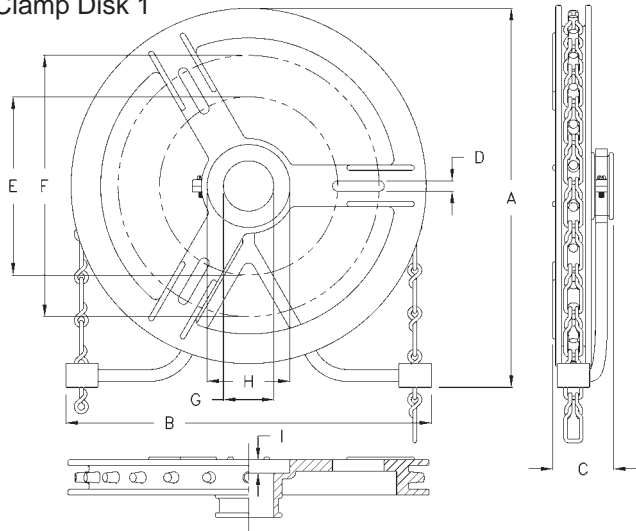

For Direct Mount Applications

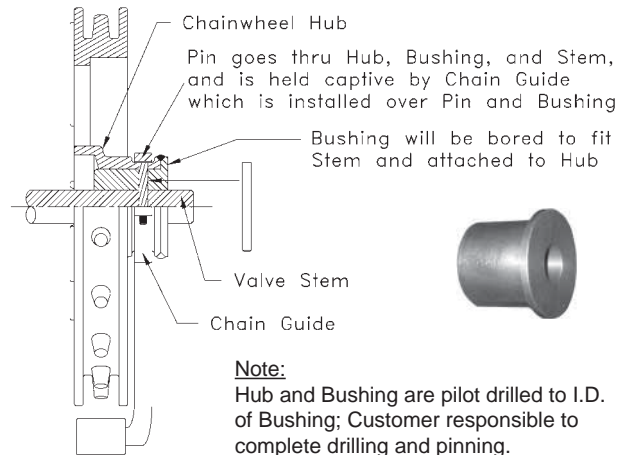

Machined Ductile Iron Bushing, shown with standard "min." round bore. Other bore sizes, shapes, tapers or keyways can be provided.

Attachment Sets

Chainwheel Sizes TR-1.5 thru TR-2.5 use two sets of Clamp Bases & Arms, plus one Band.

Chainwheel Sizes TR-3.0 thru TR-5.0 use three sets of Clamp Bases & Arms, and do not use a Band.

