



# 87A-700 Series

Stainless Steel ANSI Class 300 Flanged Std. Port Ball Valve - 1-1/2" through 2"

## STANDARDS COMPLIANCE

Refer to page D-A

## STANDARD FEATURES

Refer to page D-A

## MATERIALS OF CONSTRUCTION

Description	Material
1. Body	ASTM A351 CF8M
2. Retainer	ASTM A276 Type 316
3. Ball	ASTM A276 Type 316
4. Stem	ASTM A276 Type 316
5. Packing Gland	ASTM A276 Type 316
6. Stem Seals	PTFE
7. Seats	RPTFE
8. Gland Screws	ASTM A193 B8 Class 1
9. Gland Plate	302 & 304 SS
10. Stem Nut	316 SS
11. Lever	302 & 304 SS with Vinyl Grip
12. Stem Bearing	RPTFE
13. Stop	ASTM A276 Type 316
14. Stop Screw	18-8 SS
15. Lock Plate	302 or 304 SS
16. Body Seal	RPTFE
17. Lockwasher	302 or 304 SS
18. Grounding Spring	SS

## OPTIONS AVAILABLE:

(SUFFIX)	OPTION
-01-	Standard
-14-	Side Vented Ball (See Page J-2)
-15-	Wheel Handle, Steel
-21-	UHMWPE Seats
-24-	Fire Safe (Graphite Packing and Seal)
-35-	PTFE Seats and Seals
-38-	PEEK Seats and Graphite Packing
-49-	Assembled Dry
-57-	Oxygen Cleaned
-60-	Grounded Ball and Stem
-65-	MPTFE Seats and Graphite Packing
-67-	Cleaned For Industrial Gases
-69-	Drilled and Tapped Purge Ports with Plugs
-70-	4" Extended Bonnet
-73-	316 SS Spiral Wound Gaskets w/PTFE Filler
-74-	316 SS Spiral Wound Gaskets w/Graphite Filler
-76-	Live Loaded 87A/88A Series (Lever)
-80-	Multi-Seal (Super TFE) 87A/88A Series

**For Pressure/Temperature Ratings,  
Refer to Page M-9, Graph No. 6**

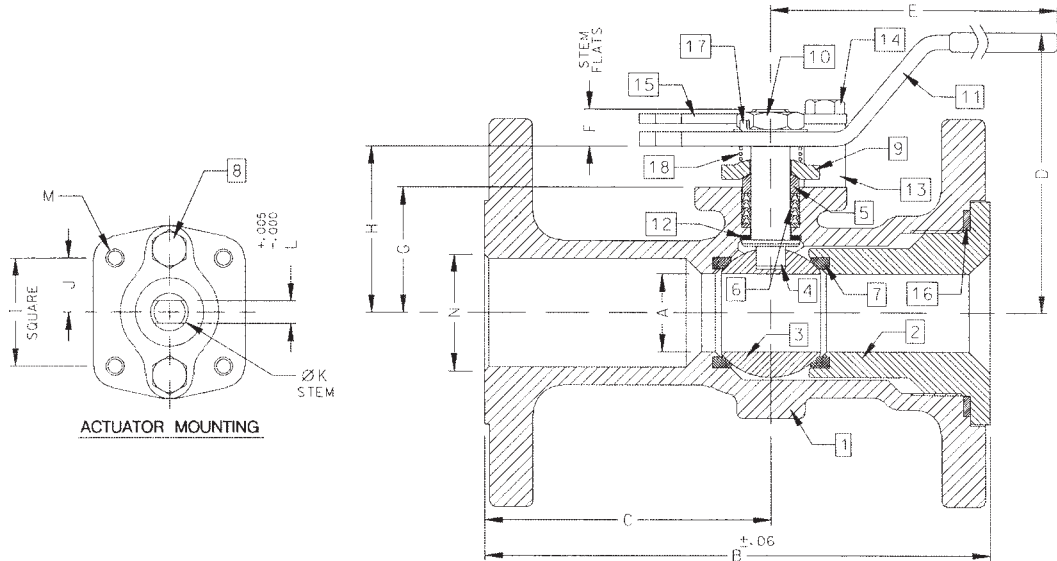

NUMBER	SIZE	A	B	C	D	E	F	G	H	I	J	K	L	M	N	WT.
87A-707-01A	1-1/2"	1.25	7.50	4.50	4.85	6.53	0.47	1.85	2.38	1.392	0.696	0.500	0.287	1/4-20	1.50	15.7
87A-708-01	2"	1.50	8.50	5.19	4.62	6.65	0.72	2.41	3.09	1.949	0.974	0.625	0.412	5/16-18	2.00	24.0



# 87A-700 Series

Stainless Steel ANSI Class 300 Flanged Std. Port Ball Valve - 2-1/2" through 3"

## STANDARDS COMPLIANCE

Refer to page D-A

## STANDARD FEATURES

Refer to page D-A

## MATERIALS OF CONSTRUCTION

Description	Material
1. Body	ASTM A351 CF8M
2. Retainer	ASTM A351 CF8M
3. Ball	ASTM A276 Type 316 or A351 CF8M
4. Stem	ASTM A276 Type 316
5. Packing Gland	ASTM A276 Type 316
6. Stem Seals	PTFE
7. Seats	RPTFE
8. Gland Screws	ASTM A193 B8 Class 1
9. Gland Plate	316 SS
10. Stem Nut	18-8 SS
11. Lever	316 with Vinyl Grip
12. Stem Bearing	RPTFE
13. Stop	ASTM A276 Type 316
14. Stop Screw	316 SS
15. Lock Plate	302 or 304 SS
16. Body Seal	RPTFE
17. Grounding Spring	SS
18. Body Joint Stud	ASTM A193 Grade B8M
19. Body Joint Nut	ASTM A194 Grade 8
20. Lockwasher	302 or 304 SS

## OPTIONS AVAILABLE:

(SUFFIX)	OPTION
-01-	Standard
-14-	Side Vented Ball (Uni-Directional)
-21-	UHMWPE Seats
-24-	Fire Safe (Graphite Packing and Seal)
-35-	PTFE Seats and Seals
-38-	PEEK Seats and Graphite Packing
-49-	Assembled Dry
-57-	Oxygen Cleaned
-60-	Grounded Ball and Stem
-65-	MPTFE Seats and Graphite Packing
-67-	Cleaned For Industrial Gases
-69-	Drilled and Tapped Purge Ports with Plugs
-70-	4" Extended Bonnet
-73-	316 SS Spiral Wound Gaskets w/PTFE Filler
-74-	316 SS Spiral Wound Gaskets w/Graphite Filler
-76-	Live Loaded 87A/88A Series (Lever)
-80-	Multi-Seal (Super TFE) 87A/88A Series
-MG-	Gear Operator with Standard Handwheel
-MH-	Gear Operator with Standard Handwheel & Locking Device
-MJ-	Gear Operator with Oversize Handwheel
-MK-	Gear Operator with Oversize Handwheel & Locking Device

**For Pressure/Temperature Ratings, Refer to Page M-9, Graph No. 6**

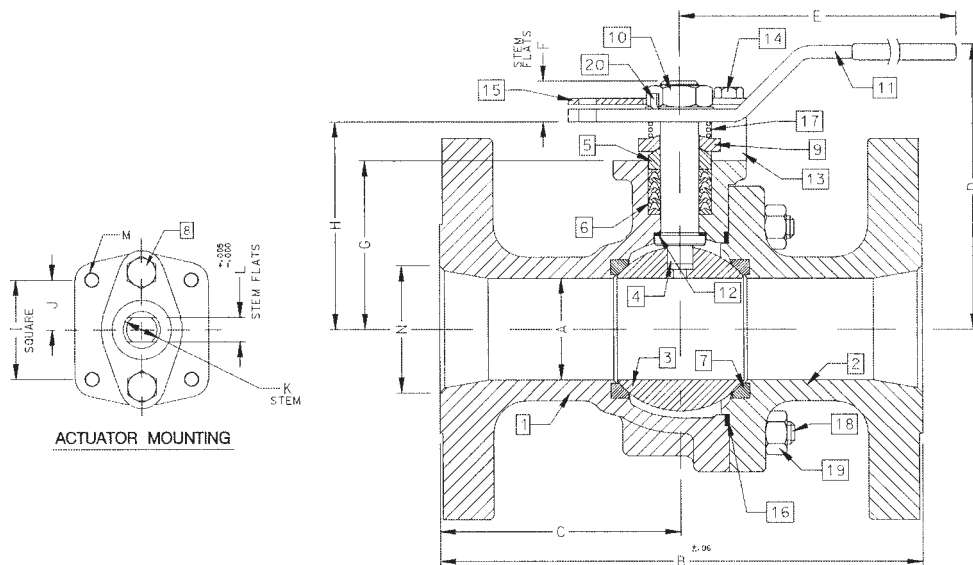

NUMBER	SIZE	A	B	C	D	E	F	G	H	I	J	K	L	M	N	WT.
87A-709-01	2-1/2"	2.00	9.50	4.75	5.61	8.41	0.80	3.31	4.08	1.949	0.974	0.750	0.477	5/16-18	2.50	39.0
87A-700-01	3"	2.50	11.12	5.56	6.24	8.41	0.80	3.94	4.71	1.949	0.974	0.750	0.477	5/16-18	3.00	55.0



# 87A-700 Series

Stainless Steel ANSI Class 300 Flanged Std. Port Ball Valve - 4" through 8"

## STANDARDS COMPLIANCE

Refer to page D-A

## STANDARD FEATURES

Refer to page D-A

## MATERIALS OF CONSTRUCTION

Description	Material
1. Body	ASTM A351 CF8M
2. Retainer	ASTM A276 Type 316
3. Ball	ASTM A276 Type 316 or A351 CF8M
4. Stem	ASTM A276 Type 316
5. Packing Gland	ASTM A276 Type 316
6. Stem Seals	PTFE
7. Seats	RPTFE
8. Gland Screws	ASTM A193 B8 Class 1
9. Gland Plate	316 SS
10. Adapter Screw	18-8 SS
11. Handle Adapter	316 SS
12. Stem Bearing	RPTFE
13. Stop	ASTM A276 Type 316
14. Stop Screw	316 SS
15. Lock Plate	302 or 304 SS
16. Body Seal	RPTFE
17. Grounding Spring	SS
18. Body Joint Stud	ASTM A193 Grade B8M
19. Body Joint Nut	ASTM A194 Grade 8
20. Adapter Screw	18-8 SS
21. Pipe Handle	Galvanized Steel (not shown)

## OPTIONS AVAILABLE:

(SUFFIX)	OPTION
-01-	Standard
-14-	Side Vented Ball (Uni-Directional)
-21-	UHMWPE Seats
-24-	Fire Safe (Graphite Packing and Seal)
-35-	PTFE Seats and Seals
-49-	Assembled Dry
-57-	Oxygen Cleaned
-60-	Grounded Ball and Stem
-65-	MPTFE Seats and Graphite Packing
-67-	Cleaned For Industrial Gases
-69-	Drilled and Tapped Purge Ports with Plugs
-70-	Extended Bonnet
-73-	316 SS Spiral Wound Gaskets w/PTFE Filler
-74-	316 SS Spiral Wound Gaskets w/Graphite Filler
-76-	Live Loaded 87A/88A Series (Lever)
-80-	Multi-Seal (Super TFE) 87A/88A Series
-MG-	Gear Operator with Standard Handwheel
-MH-	Gear Operator with Standard Handwheel & Locking Device
-MJ-	Gear Operator with Oversize Handwheel
-MK-	Gear Operator with Oversize Handwheel & Locking Device

**For Pressure/Temperature Ratings,  
Refer to Page M-9, Graph No. 6**

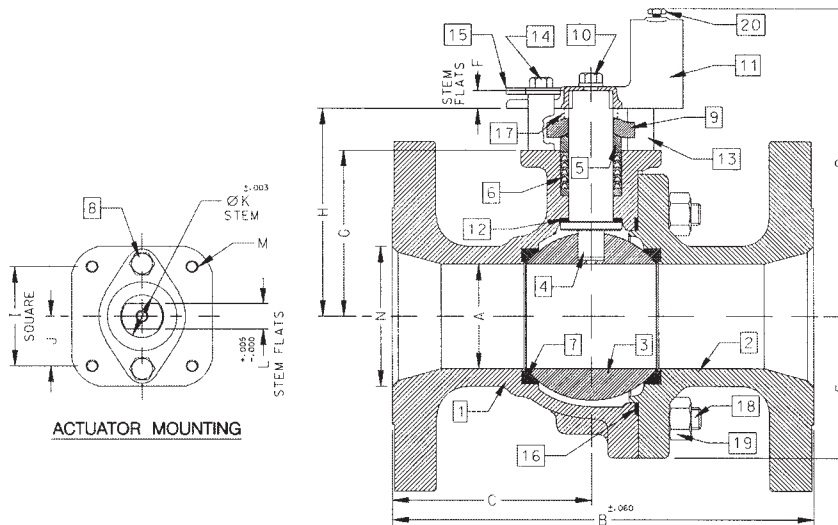

NUMBER	SIZE	A	B	C	D	E	F	G	H	I	J	K	L	M	N	WT.
87A-70A-01	4"	3.00	12.00	5.68	8.80	4.06	0.50	4.75	5.95	2.840	1.420	1.250	0.725	3/8-16	4.00	95.0
87A-70C-01	6"	4.00	15.88	7.38	9.99	5.25	0.50	5.94	7.13	2.840	1.420	1.250	0.725	3/8-16	6.00	187.0
87A-70E-01	8"	6.00	19.75	9.00	13.73	7.30	1.00	7.75	9.48	4.596	2.298	2.000	1.375	3/4-10	8.00	400.0



# 87A-700 Series

## Stainless Steel ANSI Class 300 Flanged Standard Port Ball Valve - 10"

### STANDARDS COMPLIANCE

Refer to page D-A

### STANDARD FEATURES

Refer to page D-A

### MATERIALS OF CONSTRUCTION

Description	Material
1. Body	ASTM A351 CF8M
2. Retainer	ASTM A351 CF8M
3. Ball	ASTM A276 Type 316 or A351 CF8M
4. Stem	ASTM A276 Type 316
5. Packing Gland	ASTM A276 Type 316
6. Stem Seals	PTFE
7. Seats	RPTFE
8. Gland Screws	ASTM A193 B8 Class 1
9. Gland Plate	316 SS
10. Stem Bearing	RPTFE
11. Body Seal	RPTFE
12. Body Joint Stud	ASTM A193 Grade B8M
13. Body Joint Nut	ASTM A194 Grade 8

### OPTIONS AVAILABLE:

(SUFFIX)	OPTION
-01-	Standard (Less Gear Operator)
-14-	Side Vented Ball (See Page J2)
-21-	UHMWPE Seats
-24-	Fire Safe (Graphite Packing and Seal)
-35-	PTFE Seats and Seals
-49-	Assembled Dry
-57-	Oxygen Cleaned (Stainless Steel Valves Only)
-60-	Grounded Ball and Stem
-65-	MPTFE Seats and Graphite Packing
-69-	Drilled and Tapped Purge Ports with Plugs
-70-	Extended Bonnet
-76-	Live Loaded 87A/88A Series (Lever)
-77-	Live Loaded 87A/88A Series (Gear & Actuated)
-80-	Multi-Seal (Super TFE) 87A/88A Series
-MG-	Gear Operator with Standard Handwheel
-MH-	Gear Operator with Standard Handwheel & Locking Device
-MJ-	Gear Operator with Oversize Handwheel
-MK-	Gear Operator with Oversize Handwheel & Locking Device

**For Pressure/Temperature Ratings,  
Refer to Page M-9, Graph No. 6**

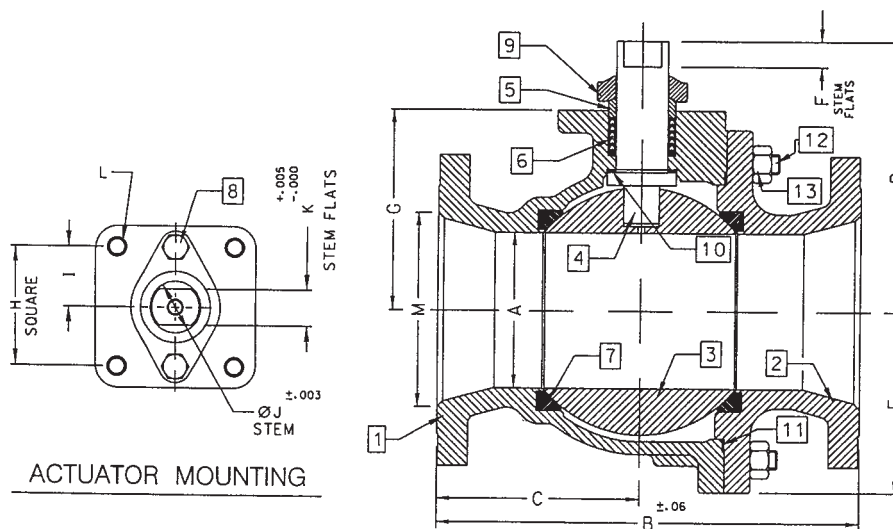

NUMBER	SIZE	A	B	C	D	E	F	G	H	I	J	K	L	M
87A-70G-01	10"	8.00	22.38	10.69	12.83	9.56	1.00	10.22	4.596	2.298	2.000	1.375	3/4-10	10.00

## Class 300 CS P-T Rating (Graph 5)

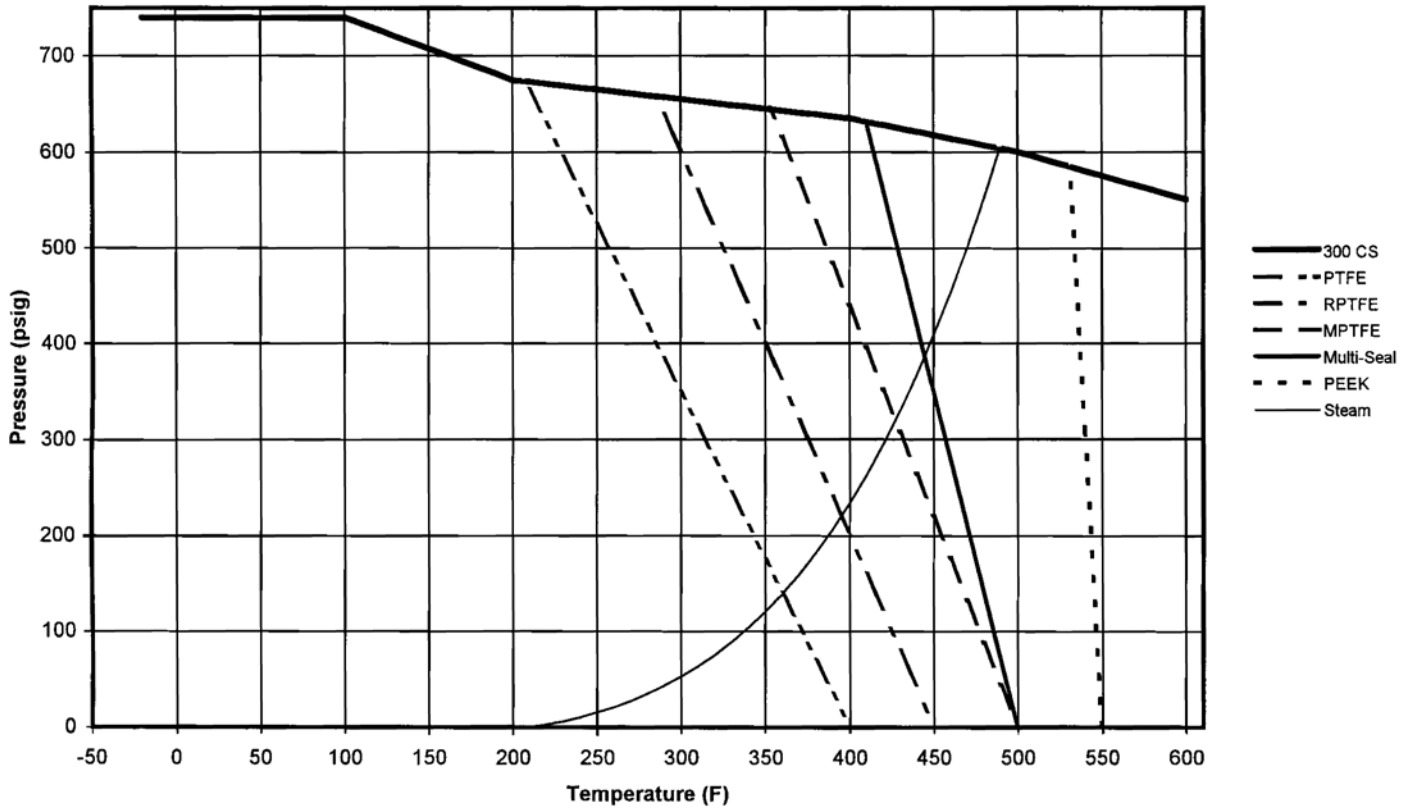

## Class 300 SS P-T Rating (Graph 6)

