



86B-100 Series

3-Piece Full Port Stainless Steel Class 600 NPT Ball Valve

Standard Compliance - Valve design: ASME B16.34, Class 600, End Connections: NPT per ASME B1.20.1, Valve Marking: ASME B16.34, Production Testing: ASME B16.34, NACE MR0175, 2000 edition.

FEATURES

- 3-Piece construction w/ enclosed fasteners
- Full port
- Stainless steel trim & hardware
- Swing-out center section
- Pressure balanced solid ball
- Compression controlled spiral wound gaskets
- Anti-blowout one piece bottom entry stem
- Statically grounded ball, stem, & body
- Two-position locking
- Adjustable multi-piece PTFE "V" style packing
- Fully machined ISO 5211 mounting
- Cast bosses on the centersection and end caps for bleed & drain ports
- Vacuum service to 29 in of Hg.
- CE mark, 1-1/4" and larger

STANDARD MATERIAL LIST

1. Body	ASTM A351-CF8M	10. Body Nuts	ASTM A194-Gr.8
2. End Caps	ASTM A351-CF3M	11. Stop Bolts	18-8 Stainless Steel
3. Ball	ASTM A276-316SS	12. Gland Bolts	ASTM A193-Gr.B8
4. Stem	ASTM A276-316SS	13. Handle Nut/Screw	300 Series Stainless Steel
5. Seat	Multi-Seal	14. Packing Gland	ASTM A276-316SS
6. Packing	PTFE	15. Gland Plate	300 Series Stainless Steel
7. Stem Bearing	PEEK/PTFE	16. Lever Handle	300 Series Stainless Steel
8. Body Gasket	PTFE Spiral Wound	17. Lock Plate	300 Series Stainless Steel
9. Body Bolts	ASTM A193-Gr.B8M3	18. Stops	300 Series Stainless Steel
		19. Int. Gmd. Spring	300 Series Stainless Steel
		20. Ext. Gmd. Spring	300 Series Stainless Steel

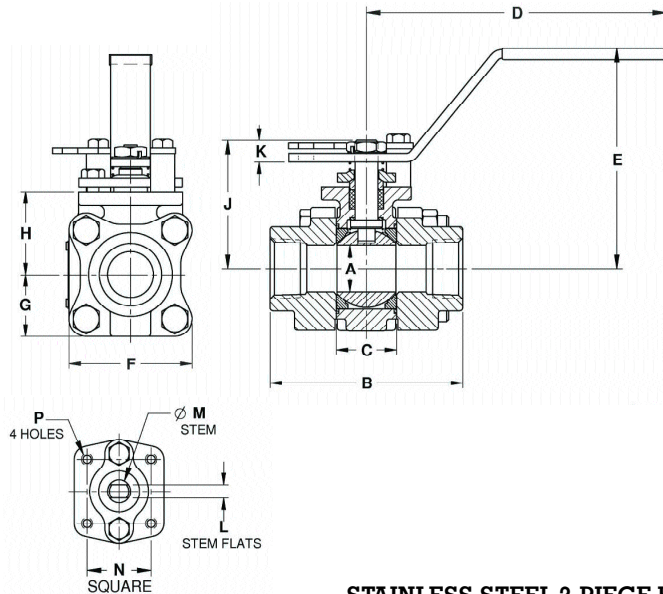

OPTIONS AVAILABLE:

(SUFFIX)	OPTION	SIZES
-04-	2-1/4" Stem Extension	3/8" to 2"
-14-	Vented Ball (see page J-2)	3/8" to 2"
-15-	Round Handle	3/8" to 2"
-21-	UHMWPE Seats w/Graphite Seals	3/8" to 2"
-24-	Fire Safe - Graphite Packing & Gaskets (API 607, 5th ed., ISO 10497-5)	3/8" to 2"
-49-	Assembled Dry	3/8" to 2"
-57-	Cleaned for Oxygen Service	3/8" to 2"
-63-	NPT x Socketweld	3/8" to 2"
-69-	Drilled & Tapped Purge & Drains	3/8" to 2"
-70-	Extended Bonnet	3/8" to 2"
-76-	Live Loaded (Lever Operated)	3/8" to 2"
-77-	Live Loaded (Actuated)	3/8" to 2"

For Pressure/Temperature Ratings,
Refer to Page M-18, Graph No. 26

STAINLESS STEEL 3-PIECE FULL PORT BALL VALVE

NUMBER	SIZE	A	B	C	D	E	F	G	H	J	K	L	M	N	P	WT.
86B-102-01	3/8"	.50	2.80	0.89	5.12	3.02	2.02	1.01	1.39	1.97	0.23	0.245	0.375	1.00	10-24	2.3
86B-103-01	1/2"	.50	2.80	0.89	5.12	3.02	2.02	1.01	1.39	1.97	0.23	0.245	0.375	1.00	10-24	2.3
86B-104-01	3/4"	0.75	3.68	1.10	5.53	3.40	2.40	1.20	1.65	2.35	0.24	0.312	0.500	1.392	1/4-20	4.0
86B-105-01	1"	1.00	4.19	1.31	6.53	4.80	2.67	1.34	1.80	2.80	0.48	0.287	0.500	1.392	1/4-20	5.7
86B-106-01	1-1/4"	1.50	4.50	1.97	6.65	4.70	3.84	1.92	2.49	3.89	0.72	0.412	0.625	1.949	5/16-18	14.2
86B-107-01	1-1/2"	1.50	4.98	1.97	6.65	4.70	3.84	1.92	2.49	3.89	0.72	0.412	0.625	1.949	5/16-18	14.4
86B-108-01	2"	2.00	5.86	2.56	8.40	5.47	4.92	2.46	3.17	4.74	0.80	0.477	0.750	1.949	5/16-18	27.6

**ASME Class 600 Carbon Steel
3 Piece Ball Valve
(Graph 25)**

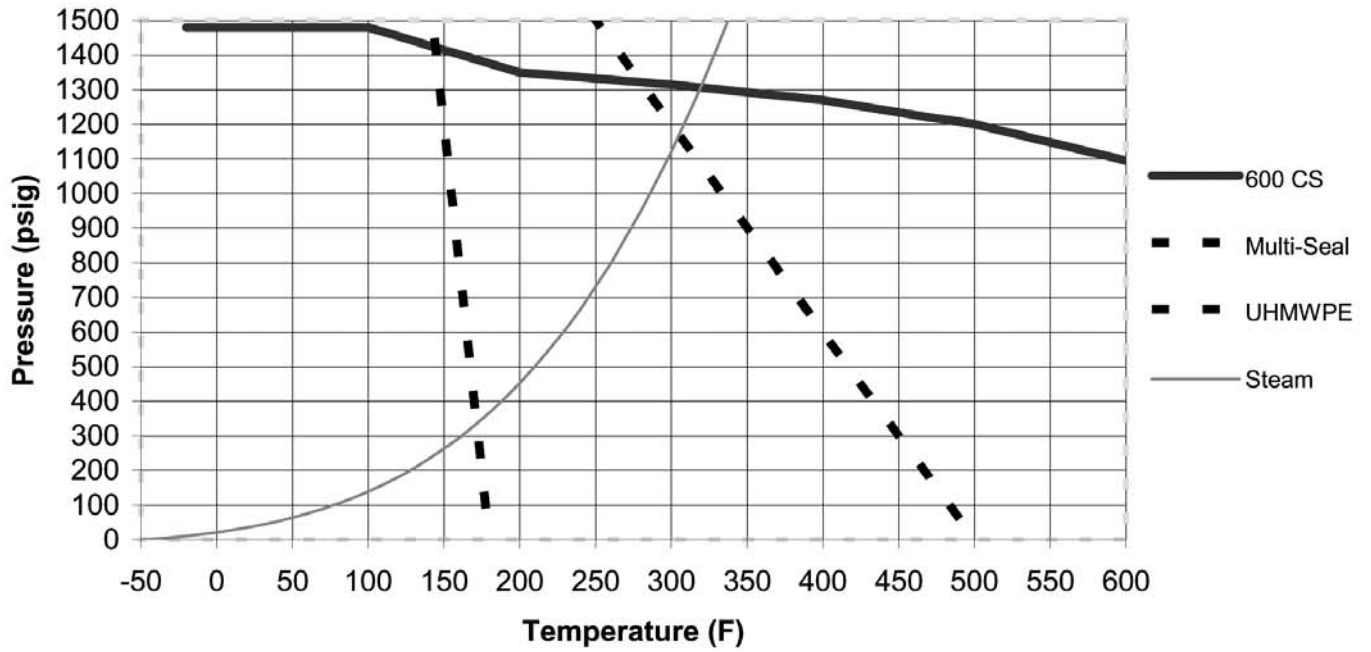

**ASME Class 600 Stainless Steel
3 Piece Ball Valve
(Graph 26)**

