



83B-540 Series

3-Piece Full Port Carbon Steel Class 600 Butt-Weld Ball Valve

Standard Compliance - Valve design: ASME B16.34, Class 600, End Connections: Butt-weld per ASME B16.25, Valve Marking: ASME B16.34, Production Testing: ASME B16.34, NACE MR0175, 2000 edition.

FEATURES

- 3-Piece construction w/ enclosed fasteners
- Full port
- Stainless steel trim & hardware
- Swing-out center section
- Pressure balanced solid ball
- Compression controlled spiral wound gaskets
- Anti-blowout one piece bottom entry stem
- Statically grounded ball, stem, & body
- Two-position locking
- Adjustable multi-piece PTFE "V" style packing
- Fully machined ISO 5211 mounting
- Cast bosses on the centersection and end caps for bleed & drain ports
- Vacuum service to 29 in. of Hg.
- CE mark, 1-1/4" and larger

STANDARD MATERIAL LIST

- | | |
|-----------------|-------------------|
| 1. Body | ASTM A216-WCB |
| 2. End Caps | ASTM A216-WCB |
| 3. Ball | ASTM A276-316SS |
| 4. Stem | ASTM A276-316SS |
| 5. Seat | Multi-Seal |
| 6. Packing | PTFE |
| 7. Stem Bearing | PEEK/PTFE |
| 8. Body Gasket | PTFE Spiral Wound |
| 9. Body Bolts | ASTM A193-Gr.B8M3 |

- | | |
|----------------------|----------------------------|
| 10. Body Nuts | ASTM A194-Gr.8 |
| 11. Stop Bolts | 18-8 Stainless Steel |
| 12. Gland Bolts | ASTM A193-Gr.B8 |
| 13. Handle Nut/Screw | 300 Series Stainless Steel |
| 14. Packing Gland | ASTM A276-316SS |
| 15. Gland Plate | 300 Series Stainless Steel |
| 16. Lever Handle | 300 Series Stainless Steel |
| 17. Lock Plate | 300 Series Stainless Steel |
| 18. Stops | 300 Series Stainless Steel |
| 19. Int. Gmd. Spring | 300 Series Stainless Steel |
| 20. Ext. Gmd. Spring | 300 Series Stainless Steel |

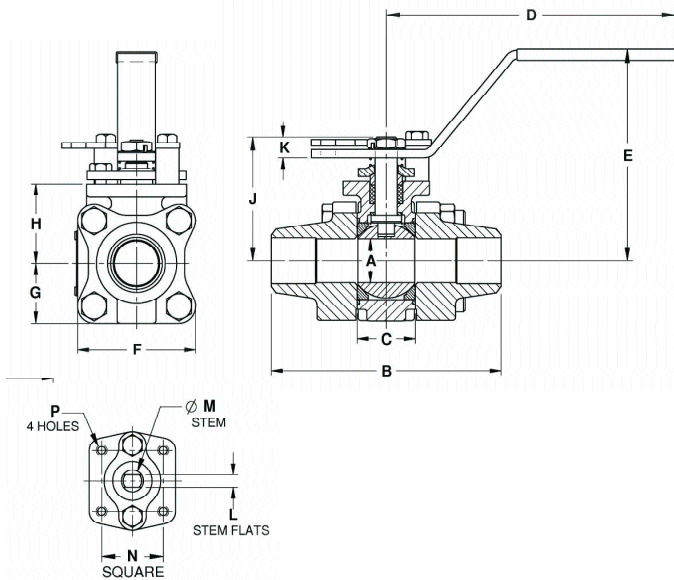

VARIATIONS AVAILABLE:

- 83B-340 - Schedule 5 Butt-weld
- 83B-440 - Schedule 10 Butt-weld
- 83B-640 - Schedule 80 Butt-weld

OPTIONS AVAILABLE:

(SUFFIX)	OPTION	SIZES
-04	2-1/4" Stem Extension	3/8" to 2"
-14	Vented Ball (see page J-2)	3/8" to 2"
-15	Round Handle	3/8" to 2"
-21	UHMWPE Seats w/Graphite Seals	3/8" to 2"
-24	Fire Safe - Graphite Packing & Gaskets (API607, 5th ed., ISO 10497-5)	3/8" to 2"
-49	Assembled Dry	3/8" to 2"
-67	Cleaned for Industrial Gases	3/8" to 2"
-69	Drilled & Tapped Purge & Drains	3/8" to 2"
-70	Extended Bonnet	3/8" to 2"
-76	Live Loaded (Lever Operated)	3/8" to 2"
-77	Live Loaded (Actuated)	3/8" to 2"

**For Pressure/Temperature Ratings,
Refer to Page M-18, Graph No. 25**

CARBON STEEL 3-PIECE FULL PORT BALL VALVE

NUMBER	SIZE	A	B	C	D	E	F	G	H	J	K	L	M	N	P	WT.
83B-542-01	3/8"	.50	3.80	0.89	5.12	3.02	2.02	1.01	1.39	1.97	0.23	0.245	0.375	1.00	10-24	2.3
83B-543-01	1/2"	.50	3.80	0.89	5.12	3.02	2.02	1.01	1.39	1.97	0.23	0.245	0.375	1.00	10-24	2.3
83B-544-01	3/4"	0.75	4.66	1.10	5.53	3.40	2.40	1.20	1.65	2.35	0.24	0.312	0.500	1.392	1/4-20	4.0
83B-545-01	1"	1.00	5.19	1.31	6.53	4.80	2.67	1.34	1.80	2.80	0.48	0.287	0.500	1.392	1/4-20	5.7
83B-546-01	1-1/4"	1.50	5.48	1.97	6.65	4.70	3.84	1.92	2.49	3.89	0.72	0.412	0.625	1.949	5/16-18	14.2
83B-547-01	1-1/2"	1.50	5.96	1.97	6.65	4.70	3.84	1.92	2.49	3.89	0.72	0.412	0.625	1.949	5/16-18	14.4
83B-548-01	2"	2.00	6.84	2.56	8.40	5.47	4.92	2.46	3.17	4.74	0.80	0.477	0.750	1.949	5/16-18	27.6

**ASME Class 600 Carbon Steel
3 Piece Ball Valve
(Graph 25)**

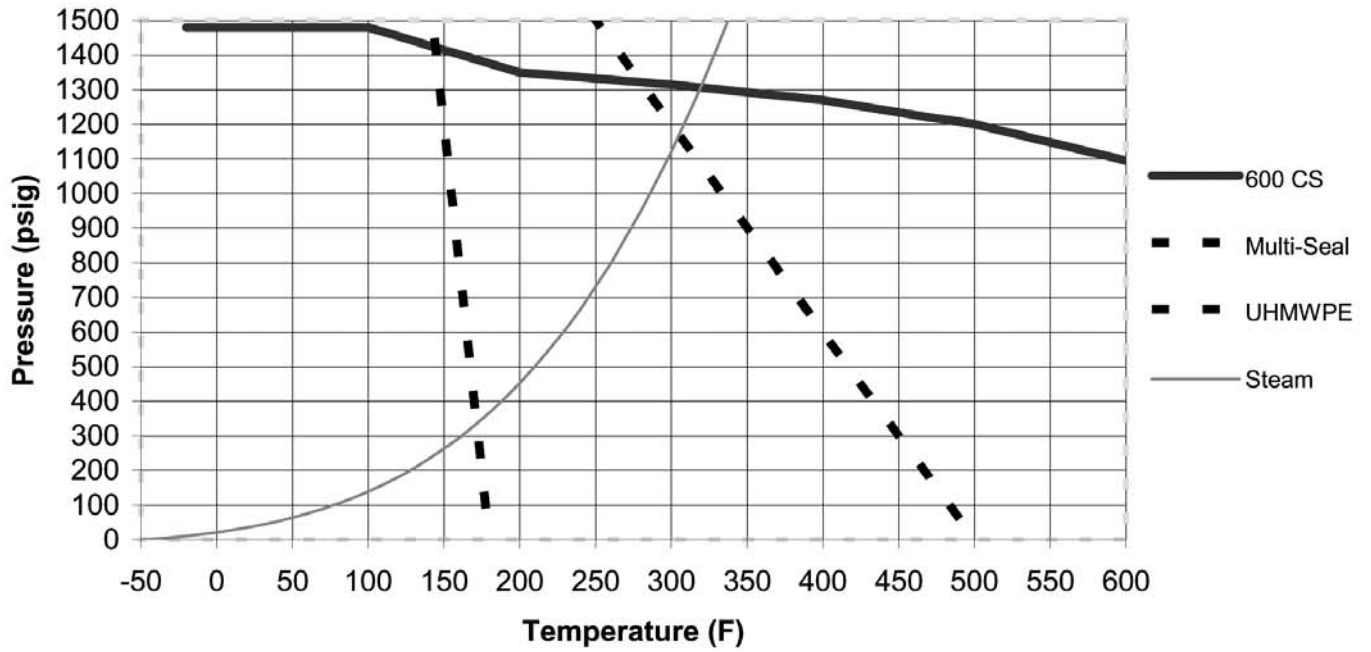

**ASME Class 600 Stainless Steel
3 Piece Ball Valve
(Graph 26)**

