



70-100 Series Bronze Ball Valve

Threaded, 600 psig WOG, Cold Non-Shock. 150 psig Saturated Steam. (See referenced P/T charts)
Vacuum Service to 29 inches Hg.

Federal Specification: WW-V-35C, Type: II, Composition: BZ, Style: 3.

MSS SP-110; Ball Valves Threaded, Socket-Welding, Solder Joint, Grooved and Flared Ends.

FEATURES

- Chromium plated ball
- RPTFE seats and stuffing box ring
- Blow-out-proof stem design
- Adjustable packing gland

STANDARD MATERIAL LIST

1. Lever and grip	Steel, zinc plated w/vinyl	7. Gland nut	B16
2. Stem packing	RPTFE	8. Stem	B16
3. Stem bearing	RPTFE	9. Lever nut	Steel, zinc plated
4. Ball	B16, chrome plated	10. Body seal	PTFE
5. Seat (2)	RPTFE	(1-1/4" to 3")	
6. Retainer	B16 (1/4" to 1")	11. Body	B584-C84400
	B584-C84400 (1-1/4" to 3")		

VARIATIONS AVAILABLE:

- 70-120 Series (Adjustable Stop Lever)
- 70-140 Series (316 SS Ball & Stem)
- 70-150 Series (Balancing Stop)
- 70-190 Series (Locked Retainer)

OPTIONS AVAILABLE:

(SUFFIX)	OPTION	SIZES
-02-	Stem Grounded	1/4" to 3"
-03-	1-1/4" CS Stem Extension	1/4" to 3"
-04-	2-1/4" CS Stem Extension	1/4" to 3"
-05-	Plain Ball	1/4" to 3"
-07-	Steel Tee Handle	1/4" to 2"
-08-	90° Reversed Stem	1/4" to 3"
-10-	SS Lever & Nut	1/4" to 3"
-14-	Side Vented Ball (Uni-Directional)	1/4" to 3"
-15-	Wheel Handle, Steel	1/4" to 2"
-16-	Chain Lever - Vertical	3/4" to 2"
-17-	Rough Chrome Plated - Bronze Valves	1/4" to 3"
-21-	UHMWPE Trim (Non-PTFE)	1/4" to 3"
-24-	Graphite Packing	1/4" to 3"
-27-	SS Latch-Lock Lever & Nut	1/4" to 3"
-30-	Cam-Lock and Grounded	1/4" to 2"
-32-	SS Tee Handle & Nut	1/4" to 2"
-35-	VTFE Trim	1/4" to 3"
-36-	SS Hi-Rise Round Handle, SS Nut	1/4" to 2"
-39-	SS Hi-Rise Locking Wheel Handle, SS Nut	1/4" to 2"
-40-	Cyl-Loc and Grounded	1/4" to 2"
-41-	Automatic Drain (Bronze Valves Only)	1/4" to 2"
	see page J-8	
-45-	Less Lever & Nut	1/4" to 3"
-46-	Latch Lock Lever - Lock in Closed Position Only	1/4" to 3"
-47-	SS Oval Latch-Lock Handle & Nut	1/4" to 1"
-48-	SS Oval Handle (No Latch) & Nut	1/4" to 2"
-49-	Assembled Dry	1/4" to 3"
-50-	2-1/4" CS Locking Stem Extension	1/4" to 3"
-56-	Multifill Seats & Packing	1/4" to 3"
-57-	Oxygen Cleaned	1/4" to 3"
-58-	Chain Lever - Horizontal	3/4" to 2"
-60-	Static Grounded Ball & Stem	1/4" to 3"
-63-	NPT x Solder/Socket Weld	3/8" to 3"
-64-	250# Steam Trim	1/4" to 3"
-P01-	BSPP (Parallel) Thread Connection	1/4" to 3"
-T01-	BSPT (Tapered) Thread Connection	1/4" to 3"

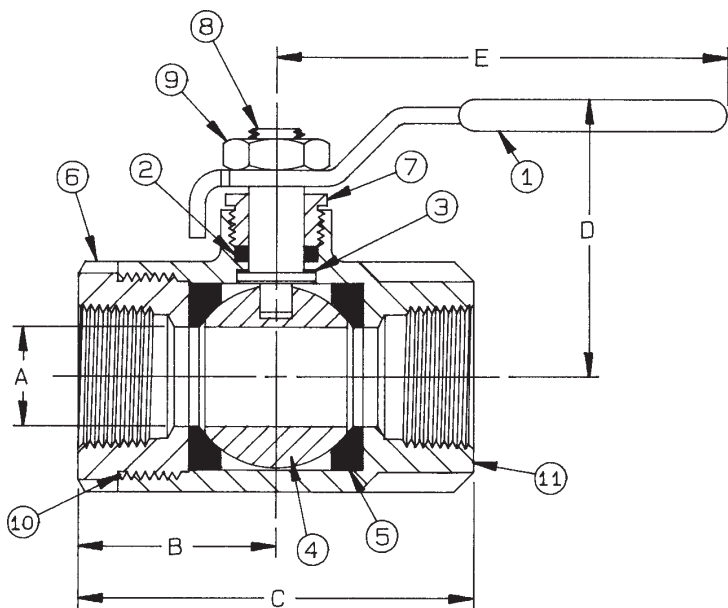

BRONZE BALL VALVE

NUMBER	SIZE	A	B	C	D	E	Wt.
70-101-01	1/4"	.37	1.03	2.06	1.75	3.87	.60
70-102-01	3/8"	.37	1.03	2.06	1.75	3.87	.56
70-103-01	1/2"	.50	1.12	2.25	1.75	3.87	.63
70-104-01	3/4"	.68	1.50	3.00	2.12	4.87	1.39
70-105-01	1"	.87	1.68	3.37	2.25	4.87	1.72
70-106-01	1-1/4"	1.00	2.00	4.00	2.62	5.50	3.26
70-107-01	1-1/2"	1.25	2.18	4.37	3.06	8.00	4.61
70-108-01	2"	1.50	2.34	4.68	3.25	8.00	6.06
70-109-01A	2-1/2"	2.00	3.12	6.25	3.72	8.00	17.25
70-100-01	3"	2.50	3.37	6.75	4.12	8.00	18.60
70-10A-01	4"	3.12	3.68	7.37	5.25	10.00	25.50

**For Pressure/Temperature Ratings,
Refer to Page M-8, Graph No. 4**

400# Bronze P-T Rating (Graph 3)

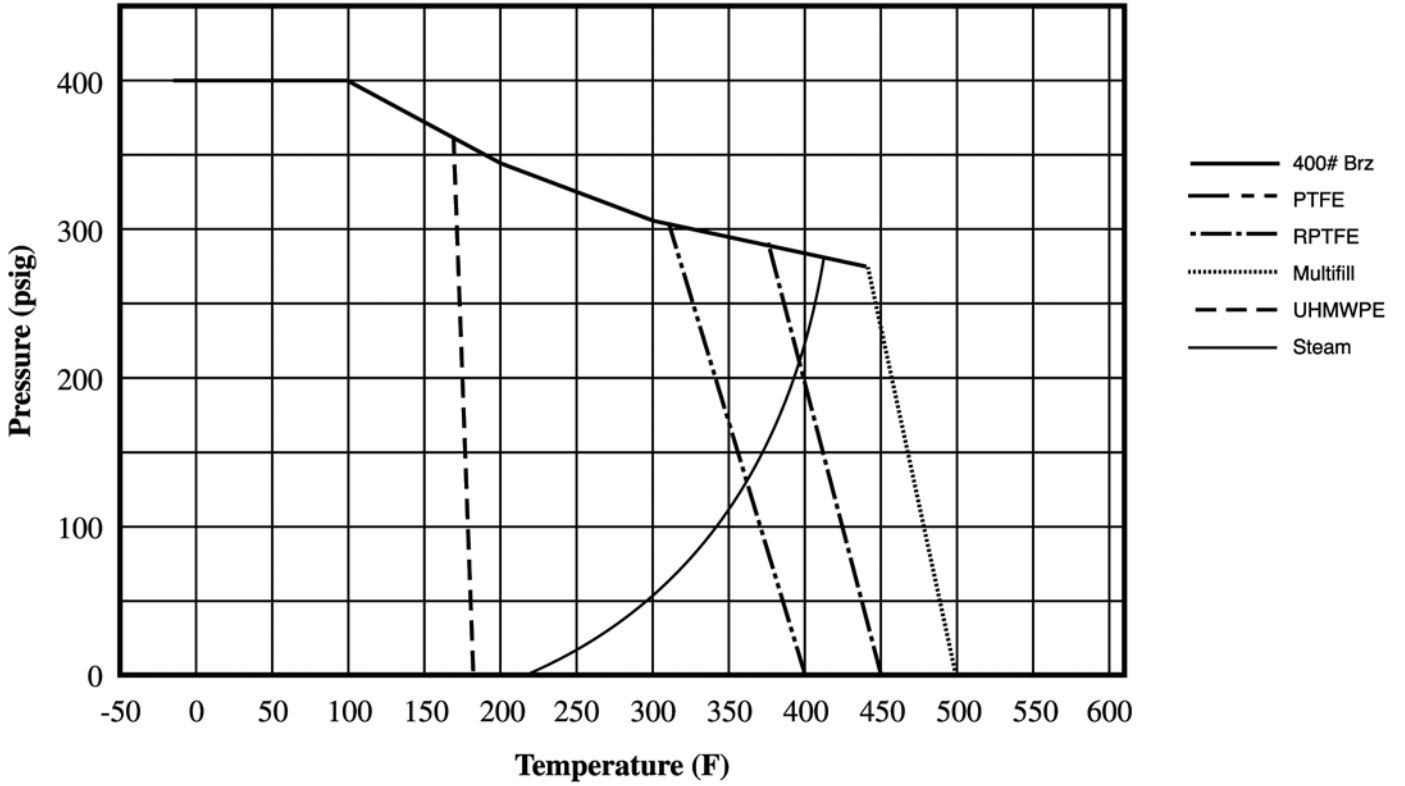

600# Bronze P-T Rating (Graph 4)

