

**Class 250 • Bolted Bonnet • OS&Y • Bronze Trim • Flanged Ends**

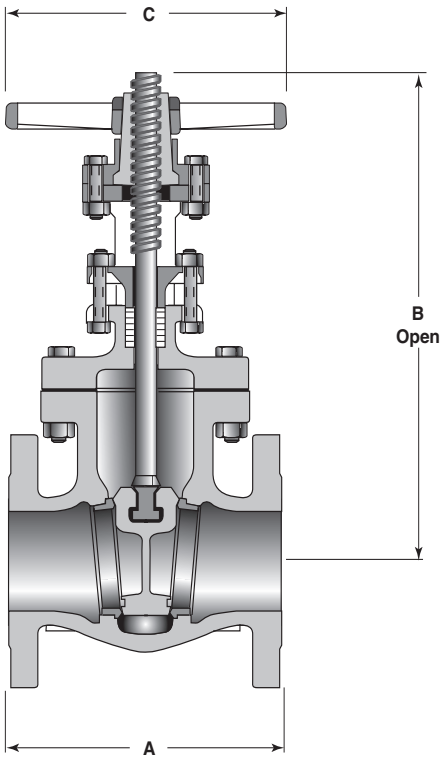

**Figure 7½E**  
Flanged with Bronze Trim  
**Size Range:**  
2 through 12 inches

**Working Pressures Non-Shock**  
250 psi Steam, Basic Rating  
500 psi Cold Working Pressure

**Features**

- Tapered Solid Wedge Disc
- Body Guide Ribs
- Non Asbestos Packing and Gaskets
- Bronze Stem
- Renewable Bronze Seat Rings
- ACME Double Stem Threads
- Valves can be equipped with by-passes when specified.
- Valves 6" and larger have bosses cast into the bodies and bonnets, and can be equipped with taps and drains to prevent fluids from accumulating and possibly causing damage. Orders must specify location of taps and drains.
- MSS SP-70 Type 1 and MSS SP-25 ASME B16.10, ASME B16.1

For more detailed features, refer to page 7.

**Principal Parts & Materials**

Fig. No.	Size	Stem	Seating	End Conn.
7½E	2" - 12"	Bronze	Bronze	Flanged

**Dimensions and Weights**

Inches (millimeters) - pounds (kilograms)

Valves	2 (50)	2 ½ (65)	3 (80)	4 (100)	5 (125)	6 (150)	8 (200)	10 (250)	12 (300)
A	8.50 (216)	9.50 (241)	11.12 (282)	12.00 (305)	15.00 (381)	15.88 (403)	16.50 (419)	18.00 (457)	19.75 (502)
B	15.06 (382)	16.69 (424)	18.75 (476)	23.44 (595)	24.00 (609)	31.75 (806)	39.88 (1012)	41.75 (1060)	47.00 (1193)
C	8.00 (203)	8.00 (203)	10.00 (254)	12.00 (305)	14.00 (356)	16.00 (406)	18.00 (457)	22.00 (559)	24.00 (610)
Wt.	54 (24)	80 (36)	114 (52)	174 (79)	280 (127)	332 (151)	600 (270)	920 (417)	1400 (635)