

Class 300 • Union Bonnet • Rising Stem • Stainless Steel Seats • Threaded

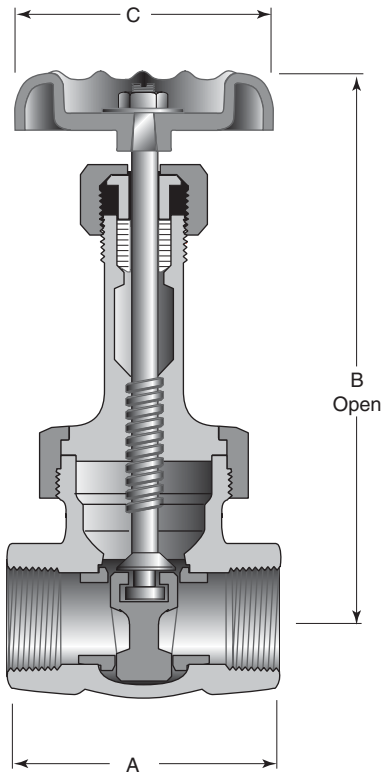

Features

- Rising Stem
- Union Bonnet
- Bolted Bonnet (2 1/2" to 3")
- Solid Wedge Disc
- Threaded Ends
- Full Ports
- Back Seat
- 410 Stainless Steel Seat Rings
- MSS SP-80, Type 2

For more detailed features, refer to page 18.

Figure 634E

Size Range:

1/4" through 3"

Working Pressures Non-Shock:

300 psi Steam, Basic Rating

1000 psi Cold Working Pressure

1/4" to 2" - (6mm - 50mm)

600 psi Cold Working Pressure

2 1/2" to 3" - (65mm - 80mm)

Principal Parts & Materials

Part	Sizes	Material	ASTM
Body & bonnet	All	Bronze	B61 alloy C92200
Disc	All	Bronze	B61 alloy C92200
Seat ring	All	410 Stainless Steel	A276 S41000
Stem	All	Bronze	B371 alloy C69400

Dimensions and Weights

Inches (millimeters) - pounds (kilograms)

	1/4 (6)	3/8 (10)	1/2 (15)	3/4 (20)	1 (25)	1 1/4 (32)	1 1/2 (40)	2 (50)	2 1/2 (65)	3 (80)
A	2.03 (52)	2.13 (54)	2.42 (61)	2.61 (66)	3.06 (78)	3.35 (85)	3.69 (94)	3.96 (101)	4.60 (117)	5.63 (143)
B	4.86 (123)	4.86 (123)	5.40 (137)	6.60 (168)	7.91 (201)	9.32 (237)	10.45 (265)	13.38 (340)	14.12 (359)	16.78 (426)
C	2.25 (57)	2.25 (57)	2.25 (57)	2.75 (70)	2.75 (70)	3.25 (83)	4.00 (102)	4.00 (102)	4.75 (121)	7.00 (178)
WTS.	.85 (0.39)	.94 (0.43)	1.44 (0.65)	2.06 (0.94)	3.34 (1.52)	4.81 (2.18)	6.13 (2.78)	10.44 (4.74)	20.50 (9.31)	44.00 (19.95)