

K-FLO

BUTTERFLY VALVES

VALVES FROM 3" THRU 168"



MEETS AND EXCEEDS
THE LATEST AWWA C504 EDITION



PO Box 411
Berwick PA 18603

S2 - Shaft Dia., 150B
S3 - Shaft Dia., 250B

dia.
es
es
B)
(s)
s)

45°
D

K
F
SIZES 3" & 4" ONLY

que Plug

B

800-247-VALV
www.crispinvalve.com

500 SERIES: Sizes 3"-20" Available

The K-Flo 500 Series is a heavy-duty resilient seated butterfly valve line in full compliance with AWWA C504 for use in municipal, power and industrial applications. Every K-Flo 500 Series butterfly valve is tested for performance, as well as seat and body leakage; and all of the valves meet or exceed the latest AWWA C504 standards and requirements. The 500 Series valves are available in flanged or mechanical joint configurations.

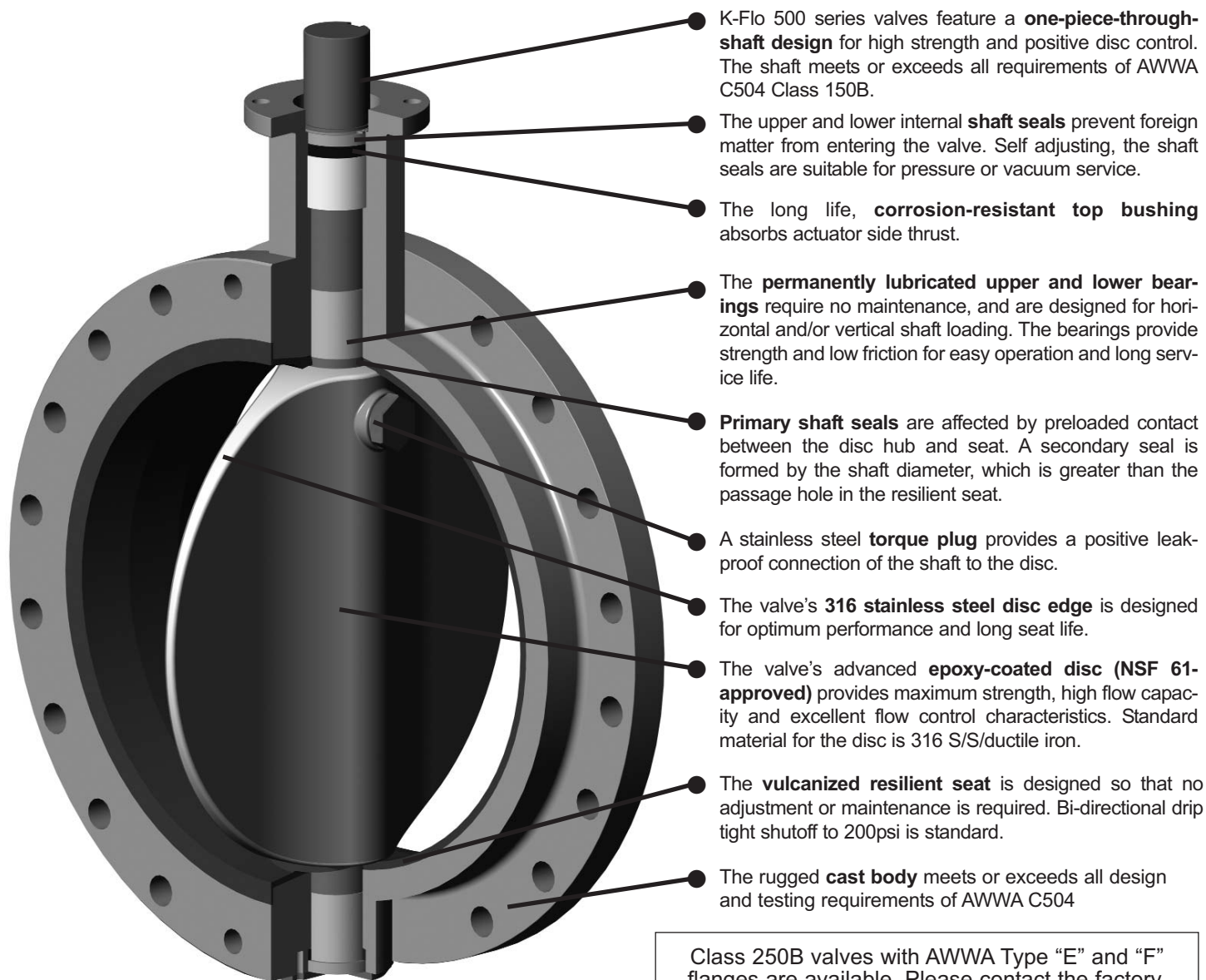

K-Flo 500 series valves feature a **one-piece-through-shaft design** for high strength and positive disc control. The shaft meets or exceeds all requirements of AWWA C504 Class 150B.

The upper and lower internal **shaft seals** prevent foreign matter from entering the valve. Self adjusting, the shaft seals are suitable for pressure or vacuum service.

The long life, **corrosion-resistant top bushing** absorbs actuator side thrust.

The **permanently lubricated upper and lower bearings** require no maintenance, and are designed for horizontal and/or vertical shaft loading. The bearings provide strength and low friction for easy operation and long service life.

Primary shaft seals are affected by preloaded contact between the disc hub and seat. A secondary seal is formed by the shaft diameter, which is greater than the passage hole in the resilient seat.

A stainless steel **torque plug** provides a positive leak-proof connection of the shaft to the disc.

The valve's **316 stainless steel disc edge** is designed for optimum performance and long seat life.

The valve's advanced **epoxy-coated disc (NSF 61-approved)** provides maximum strength, high flow capacity and excellent flow control characteristics. Standard material for the disc is 316 S/S/ductile iron.

The **vulcanized resilient seat** is designed so that no adjustment or maintenance is required. Bi-directional drip tight shutoff to 200psi is standard.

The rugged **cast body** meets or exceeds all design and testing requirements of AWWA C504

Class 250B valves with AWWA Type "E" and "F" flanges are available. Please contact the factory.

MATERIALS

SIZES

3"-20" (meets or exceeds AWWA C504)

BODY

Cast Iron (ASTM A126, Class B); Ductile Iron (optional); (ASTM A536 Grade 65/45/12)

SEAT

Seating of Synthetic Rubber bonded to body. Buna-N standard; EPDM optional (tested in accordance with ASTM D429, Method B)

UPPER STEM BUSHING

Polyester

SHAFT

Stainless Steel (ASTM A276): Grade 304 standard, Grade 316 optional; 17-4pH on Class 250B

DISC

316 Stainless standard on 3"-8". Ductile Iron (ASTM A536, Grade 65-45-12) with a 316 Stainless Steel Edge on sizes 10"-20". Iron discs are coated with an epoxy for extra long product life

BEARINGS

316 Stainless Steel; TFE Lined

500 SERIES: Dimensional Data

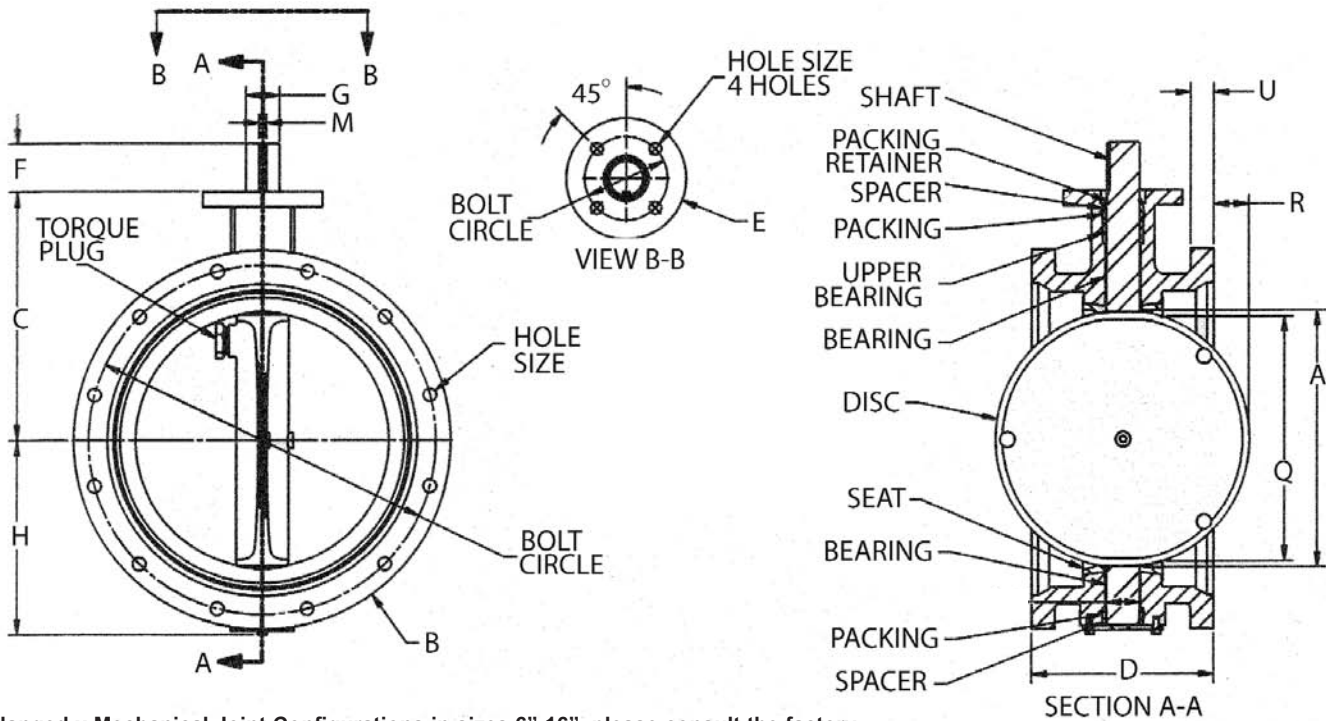

For Flanged x Mechanical Joint Configurations in sizes 6"-16", please consult the factory.

K-FLO Model 504 (Flanged x Flanged)

* All dimensions are in INCHES

Size	A	B	C	D	E	F	G	H	M	Q	R	U	TOP PLATE			FLANGE DRILLING				Bare Shaft Wt. lbs.	
													Bolt Circle	Hole Size	ISO 5211	Bolt Circle	# of Holes	Hole Size	Tapped Holes		Thread Size
3	2 ³ / ₄	7 ¹ / ₂	6 ⁵ / ₁₆	5	4	1 ¹ / ₂	9 ⁹ / ₁₆	3 ³ / ₄	1/8sq	n/a	n/a	9 ⁹ / ₁₆	2.756	11 ¹ / ₃₂	F 07	6	4	3/4	n/a	n/a	29
4	3 ⁹ / ₁₆	9	7 ¹ / ₁₆	5	4	1 ¹ / ₂	9 ⁹ / ₁₆	4 ¹ / ₂	1/8sq	n/a	n/a	5 ⁵ / ₁₆	2.756	11 ¹ / ₃₂	F 07	7 ¹ / ₂	8	3/4	n/a	n/a	48
6	5 ¹ / ₂	11	8 ¹ / ₁₆	5	6	2	1 ¹ / ₈	6	1/4sq	2 ³ / ₄	5 ⁵ / ₁₆	1 ¹ / ₈	4.921	9 ⁹ / ₁₆	F 12	9 ¹ / ₂	8	7/8	n/a	n/a	58
8	7 ¹ / ₂	13 ¹ / ₂	9 ⁹ / ₁₆	6	6	2	1 ¹ / ₈	6 ³ / ₄	1/4sq	4 ⁷ / ₈	13 ¹³ / ₁₆	1 ¹ / ₈	4.921	9 ⁹ / ₁₆	F 12	11 ³ / ₄	8	7/8	n/a	n/a	96
10	9 ⁵ / ₈	16	10 ¹³ / ₁₆	8	6	2 ¹ / ₂	1 ³ / ₈	8	5/16sq	5 ⁵ / ₈	13 ¹³ / ₁₆	1 ³ / ₈	4.921	9 ⁹ / ₁₆	F 12	14 ¹ / ₄	12	1	n/a	n/a	150
12	11 ³ / ₈	19	12 ⁵ / ₁₆	8	6	2 ⁹ / ₁₆	1 ³ / ₈	9 ¹ / ₂	5/16sq	8 ³ / ₈	11 ¹¹ / ₁₆	1 ¹ / ₂	4.921	9 ⁹ / ₁₆	F 12	17	12	1	n/a	n/a	204
14	12 ¹⁵ / ₁₆	21	14 ¹ / ₁₆	8	8	2 ³ / ₈	1 ⁵ / ₈	10 ¹ / ₂	3/8sq	10 ¹ / ₂	2 ¹ / ₂	1 ³ / ₄	6.496	13 ¹³ / ₁₆	F 16	18 ³ / ₄	12	1 ¹ / ₈	n/a	n/a	267
16	15 ¹ / ₈	23 ¹ / ₂	15 ¹ / ₁₆	8	8	2 ¹¹ / ₁₆	1 ⁷ / ₈	11 ³ / ₄	1/2 x 3/8	13 ¹³ / ₁₆	3 ⁵ / ₈	2	6.496	13 ¹³ / ₁₆	F 16	21 ¹ / ₄	16	1 ¹ / ₈	4	1"-8	354
18	16 ¹⁵ / ₁₆	25	16 ⁹ / ₁₆	8	8	3 ³ / ₁₆	2 ¹ / ₄	13 ¹ / ₁₆	1/2 x 3/8	15 ¹⁵ / ₁₆	4 ⁹ / ₁₆	2 ¹ / ₄	6.496	13 ¹³ / ₁₆	F 16	22 ³ / ₄	16	1 ¹ / ₄	4	1 ¹ / ₈ "-7	433
20	18 ⁷ / ₈	27 ¹ / ₂	18 ¹ / ₁₆	8	8	3 ³ / ₁₆	2 ¹ / ₄	14 ⁵ / ₁₆	1/2 x 3/8	17 ³ / ₈	5 ¹ / ₂	2 ¹ / ₂	6.496	13 ¹³ / ₁₆	F 16	25	20	1 ¹ / ₄	4	1 ¹ / ₈ "-7	586

K-FLO Model 506 (Mechanical Joint x Mechanical Joint)

* All dimensions are in INCHES

Size	A	B	C	D	E	F	G	H	M	Q	R	U	TOP PLATE			FLANGE DRILLING				Bare Shaft Wt. lbs.
													Bolt Circle	Hole Size	ISO 5211	Bolt Circle	# of Holes	Hole Size	Tapped Holes	
6	5 ¹ / ₂	11 ¹ / ₂	8	8 ¹ / ₂	6	2 ¹ / ₁₆	1 ¹ / ₈	6	1/4sq	4 ¹ / ₂	n/a	1 ¹ / ₈	4.921	9 ⁹ / ₁₆	F 12	9 ¹ / ₂	6	7/8		80
8	7 ¹ / ₂	13 ³ / ₄	9 ¹ / ₂	8 ⁵ / ₈	6	2	1 ¹ / ₈	8 ⁷ / ₈	1/4sq	6 ³ / ₄	n/a	1 ¹ / ₈	4.921	9 ⁹ / ₁₆	F 12	11 ³ / ₄	6	7/8		120
10	9 ⁵ / ₈	16 ¹ / ₁₆	10 ³ / ₄	9 ¹ / ₄	6	2 ⁹ / ₁₆	1 ³ / ₈	8	5/16sq	8 ³ / ₄	3 ³ / ₁₆	1 ³ / ₈	4.921	9 ⁹ / ₁₆	F 12	14	8	7/8		170
12	11 ³ / ₈	18 ⁵ / ₁₆	12 ¹ / ₄	9 ¹ / ₄	6	2 ⁹ / ₁₆	1 ³ / ₈	9 ⁹ / ₁₆	5/16sq	10 ⁹ / ₁₆	1 ¹ / ₁₆	1 ¹ / ₂	4.921	9 ⁹ / ₁₆	F 12	16 ¹ / ₄	8	7/8		230
14	12 ¹⁵ / ₁₆	20 ¹¹ / ₁₆	14	11 ¹ / ₂	8	2 ⁷ / ₁₆	1 ⁵ / ₈	10 ³ / ₈	3/8sq	12 ¹³ / ₁₆	3 ³ / ₄	1 ³ / ₄	6.496	13 ¹³ / ₁₆	F 16	18 ³ / ₄	10	7/8		300
16	15 ¹ / ₈	22 ¹⁵ / ₁₆	15	12	8	3	1 ⁷ / ₈	11 ⁷ / ₁₆	1/2 x 3/8	14 ⁵ / ₁₆	1 ⁵ / ₈	2	6.496	13 ¹³ / ₁₆	F 16	21	12	7/8		390
18	16 ¹⁵ / ₁₆	25 ¹ / ₄	16 ¹ / ₂	12 ¹ / ₄	8	3 ³ / ₁₆	2 ¹ / ₄	13 ¹ / ₁₆	1/2 x 3/8	16 ³ / ₁₆	2 ³ / ₈	2 ¹ / ₄	6.496	13 ¹³ / ₁₆	F 16	23 ¹ / ₄	12	7/8		470
20	18 ⁷ / ₈	27 ⁷ / ₁₆	18	12 ¹ / ₂	8	3 ³ / ₁₆	2 ¹ / ₄	14 ⁵ / ₁₆	1/2 x 3/8	18 ¹ / ₁₆	3 ³ / ₁₆	2 ¹ / ₂	6.496	13 ¹³ / ₁₆	F 16	25 ¹ / ₄	14	7/8		630

FLANGED X FLANGED; MECHANICAL JOINT X MECHANICAL JOINT

- "Q" Dimension is the min. allowable inside pipe diameter at the centered valve body face to protect the disc sealing edge from damage when opening valve.
- Flange drilling per ANSI B16.1 Class 125

TNA TRAVELING NUT ACTUATOR

K-Flo provides its 20" and smaller 500 series AWWA Butterfly Valves with the TNA series Traveling Nut Actuator as the standard manual operator. The TNA is designed to exceed the rigorous requirements of AWWA specifications. Unlike other market options like small-sized worm gears, the TNA offers rugged construction and clear design benefits. One key benefit is the variable torque curve generated through the operation stroke. Differing from a worm gear's constant torque production, the TNA traveling nut operator allows the valve to open and close at slower speeds, reducing the potential for line surge from faster valve operation.

The TNA also has many other helpful features including four standard 90-degree key locations to choose from when connecting the operator to the valve. This provides orientation flexibility should the need arise to re-position the actuator due to space confinements.

Available in both Above-Ground (with integral position indicator) and Buried Service configurations.

HOUSING/COVER
Cast Iron ASTM A126

STEM (INPUT SHAFT)
4140 Steel ASTM 434

YOKE
Ductile Iron ASTM A536

CROSSHEAD
4140 Steel, ASTM 434

KEY
4140 Steel, ASTM 434

SQUARE NUT (STOP)
4140 Steel ASTM 434

GUIDE RAIL
4140 Steel ASTM 434

SHAFT COLLAR
4140 Steel ASTM 434

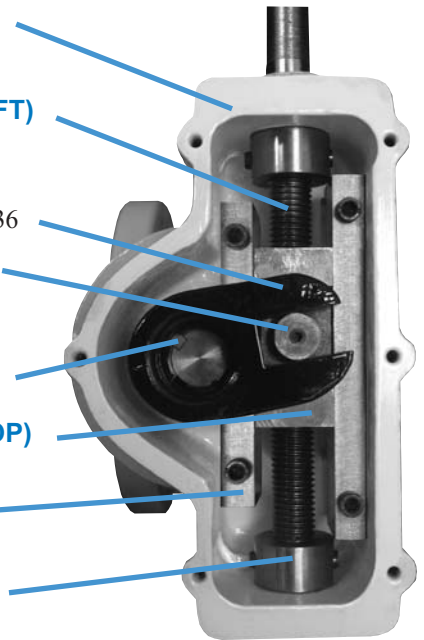

TNA ACTUATOR CHARACTERISTICS

As a butterfly valve disc approaches the closed position, the inherent design characteristics of the traveling nut type actuator cause the disc travel to slow down in relation to the turning of the operating nut or handwheel. This characteristic helps reduce the effects of water hammer caused by sudden valve closure.

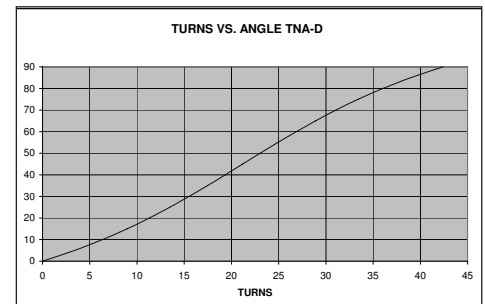
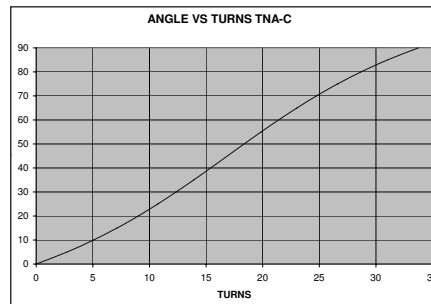
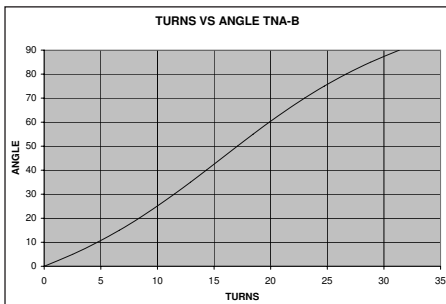

ADDITIONAL ACTUATOR OPTIONS AND EXTENSIONS

K-Flo works with all major actuator manufacturers, and we are capable of mounting any actuators--manual, electric or pneumatic--that our customers may specify. We've listed some of the more traditional actuator options below, and invite you to call us at our factory with any additional requests or questions that you may have.

MANUAL ACTUATION OPTIONS

Above Ground Manual Operators

- Lever operators with ten position selector plate. Available for valve sizes 3" thru 8".

- Handwheel and chainwheel gear operators for all valve sizes. These operators come standard with dial position indicators.

Buried and Submerged Service Gear Operators

- Buried and submerged gear operators are available for all valve sizes. These operators come standard with a 2" AWWA nut and sealed gear housing.

For gears continuously submerged at depths greater than 10 feet, please indicate specifications. This will assure the end user that a gear for the intended service is provided.

POWER OPERATORS

Cylinder Operators

- Cylinder operators are available in pneumatic or hydraulic options. They are available as double acting operators or spring return for a specific failure mode (fail open or fail close). All cylinder accessories are available for on/off or modulating service.

Electric Motor Operators

- Electric motor operators are available in numerous configurations for varied service conditions. Control options for on/off service and modulating service are available.

SUGGESTED K-FLO SPECIFICATIONS

1.00 GENERAL

1.01 WORK INCLUDED

- Furnish labor, materials, equipment and incidentals necessary to install butterfly valves.

1.02 QUALITY ASSURANCE

A. ACCEPTABLE MANUFACTURERS

1. Crispin-Kflo (Series 500 for 3" to 20" and Series 47 for 24" and larger)
2. Engineer pre-approved equal

B. EXPERIENCE REQUIREMENTS

The Manufacturer shall have had a successful experience in manufacturing tight closing Buna-N or other acceptable synthetic rubber-seated butterfly valves for this type service in the size indicated. The Manufacturer shall have at least 10 years experience in the manufacture of valves. All butterfly valves of the same type shall be the product of one Manufacturer. All materials used shall be new, of high grade, and with properties best suited to the working environment.

C. MANUFACTURER'S REPRESENTATIVE FOR STARTUP AND TESTING

The Valve Vendor or Manufacturer shall provide the services of a competent Manufacturer's representative for a sufficient period of time as required to insure proper adjustment, installation, and operation of the valve.

1.03 SUBMITTALS

A. Certificate of Compliance or complete list of all deviation from the drawings and specifications.

B. Submit installation and assembly drawings complete with seat installation details, showing the manufacturer's dimensions, weights, and loadings.

C. Submit any and all electrical schematic, wiring diagrams, and interconnection diagrams showing wiring, controls, interlocks, and terminals. Label each terminal and wire showing which control or electrical power wire connects to which terminal. Submit manufacturer's catalog data for electrical equipment and enclosures.

D. Submit flow coefficient, Cv, and maximum pressure drop at rated flow rate for each valve size used.

E. Submit manufacturer's installation instructions and certification.

F. Provide O&M manual and spare parts list with descriptive literature, including a cross-section view of valve and all operators, which indicate materials of construction, weights, principal dimensions and other important details.

2.00 PRODUCTS

2.01 BUTTERFLY VALVES

A. All butterfly valves shall be of the tight-closing, rubber-seated type, conforming to the design standards of ANSI/AWWA C504 latest revision, except where noted herein. Valves shall be bubble-tight at the rated pressure in either direction and shall be suitable for throttling service and/or operation after long periods of inactivity. Maximum operating non-shock shut-off pressure and maximum operating non-shock line pressure is 150 psi. Each valve shall be performance and leak tested as specified in AWWA C504 revised as follows: In addition to the testing requirements of AWWA C504, each butterfly valve shall be thoroughly cleaned and opened at least three (3) times prior to testing.

B. All items shall have the name or symbol of the maker, the nominal size, date of manufacture, and the working pressure for which they are designed, cast, stamped, or permanently marked on the body.

C. Butterfly valves shall be Class 150B, unless otherwise indicated and of the flanged short body design. The valve bodies shall be constructed of cast iron ASTM A-126, Class B or ductile iron in accordance with ASTM A-536 with ANSI B16.1 flange drilling or for mechanical joint ends shall conform to ANSI/AWWA C111/A21.11 standard. Flanges shall conform to AWWA Class D standards.

D. Discs for valve sizes 3" – 20" shall be of the concentric design. Valve discs shall be constructed of 316 stainless steel for sizes 3" to 8" and epoxy coated ductile iron ASTM A-536 for sizes 10" to 20". Discs for valve sizes 24" and larger shall be of the offset design to provide a full 360 degree seating surface and shall be constructed from epoxy coated ductile iron ASTM A-536. Valve disc shall have a 316 stainless steel seating edge. Valve disc shall seat at 90 degrees to the access of the pipe and shall require no torque to hold it in the closed position.

E. Valves 3" – 20" shall have a one piece through shaft constructed of stainless steel ASTM A-276, grade 304, corresponding to the requirements of AWWA C504, latest revision. The shaft shall be fastened to the disc by means of a threaded disc pin providing a positive leak proof connection of the shaft to the disc. Valves 24" and larger shall have stub shafts of stainless steel ASTM A-276, grade 304, corresponding to the design requirements of AWWA C504, latest revision. The shafts shall be fastened to the disc by straight pins that provide a .005 interference fit. The use of taper pins for the shaft/disc connection is not acceptable.

F. The resilient seat shall be Buna-N for valves 3" – 20" and shall be simultaneously bonded and vulcanized to body of the valve. All interior surfaces

in contact with water, excluding stainless steel and disc, shall be completely rubber lined. Seats for valves 3"–20" shall be designed so that they will require no internal adjustment or maintenance to seat against a pressure differential of 150 psi on either side of the valve. The resilient seat shall be Buna-N for valves 24" and larger and shall be mechanically retained in the body by means of 316 stainless steel attachment hardware. The seat shall be fully adjustable and replaceable in the field with the use of a standard wrench. No special tools shall be required. Valve seat designs in the body that require the use of epoxy to retain the seat or fillers to increase seat compression are not considered mechanically retained, field replaceable, or adjustable, and will not be accepted. Valves with seat designs that are located on the disc will not be acceptable.

G. All bearings shall be of the self-lubricating, corrosion-resistant, sleeve type. Bearings shall be designed for horizontal and/or vertical shaft loading. The valve assembly shall be furnished with a factory set two-way thrust bearing designed to center the valve disc in the valve seat at all times.

H. Shaft packing shall be of the V-type, self-adjusting type and suitable for pressure and vacuum service. Valves 24" and larger shall be designed with pull down packing which shall be fully adjustable and replaceable without removing the actuator. The packing shall be PTFE, interlocking braid, self compensating type. Stuffing boxes for pull down packing shall have a depth sufficient to accept at least four (4) rings of self-compensating type packing specifically selected for the operating pressure to be encountered.

I. The Manufacturer shall certify that the butterfly valves are capable of operating in continuous duty service under the specified pressures and flow conditions.

J. The interior of valves 3" – 20" shall be completely rubber lined. The valve disc shall either be entirely 316 stainless steel or be ductile iron with epoxy coating from an AWWA NSF-61 coating system. The use of liquid epoxy on body interior surfaces shall not be allowed. Valves 24" and larger: the interior of the valve body and the exterior of the valve disc shall be cleaned and sandblasted and lining shall be applied as per the Manufacturer's instructions. The lining material shall be in compliance with ANSI/NSF Standard 61, for contact with potable water. The lining material shall be "Pota-Pox" as manufactured by Tnemec, or equal. The interior lining shall be applied in a minimum of two coats, at 4–5 mils per coat; the total dry thickness shall be 8 – 10 mils.

K. The exterior surfaces shall be cleaned and sandblasted and coating shall be applied in accordance with the Manufacturer's instructions. Surface face cleanliness shall be inspected and any contaminants on the surface shall be removed prior to the coating operations. The coating material shall be "Pota-Pox" as manufactured by Tnemec, or equal. The coating material shall be applied in a minimum of two coats, at 4–5 mils per coat; the total dry thickness shall be 8– 10 mils.

3.00 EXECUTION

3.01 INSTALLATION

A. Valve installation shall be in strict accordance with the Manufacturer's printed recommendations, and the Contract Documents. Valve shaft shall be truly vertical or horizontal as indicated.

B. Four (4) copies of Final Operations and Maintenance Manuals are to be provided. The manuals shall include but not be limited to the following: installations and adjustment instructions; maintenance procedures and operation parameters; wiring diagrams; control diagrams; control sequence and instructions; lubrication schedule, including type, grade, temperature range, and frequency; diagrams and illustrations; test procedures, performance data; and parts list.

3.02 FIELD QUALITY CONTROL

A. Upon completion of installation of the butterfly valves an acceptance test shall be conducted to verify the satisfactory operation of the valves. The valves must perform in a manner acceptable to the Engineer before final acceptance will be made by the owner.

3.03 WARRANTY

A. The manufacturer warrants the workmanship and materials to be free from defect for a period of one (1) year from the date of shipment from the factory. The manufacturer shall replace any parts deemed defective during the said time period, provided that the product has been properly applied and used for the purpose intended. The manufacturer must be notified of the alleged defect and provided with the proper data as to the application. The manufacturer at its discretion will repair or replace the product, F.O.B. factory. The manufacturer shall not be liable to the buyer or others for any consequential or incidental damage. The unit shall not be disassembled in any way by the buyer, unless written permission and instruction is provided by the manufacturer—otherwise the warranty is void. The buyer agrees that the manufacturer shall not be liable for any loss, cost, expenses, or damages from the product, its uses, installation or replacement, instructions, labeling, technical data, description of the product, its uses or warnings or lack of any of the foregoing. No other warranties, written or oral, expressed or implied, shall apply.