

47 SERIES: Sizes 24"-168" Available

The K-Flo 47 Series butterfly valve is a large diameter valve line designed for a wide variety of liquid and gaseous applications. With over 50 years of service in the field, the K-Flo 47 series design is fully compliant with AWWA C504 requirements. Series 47 valves are available in flanged connections thru 168", and mechanical joint connections thru 48".

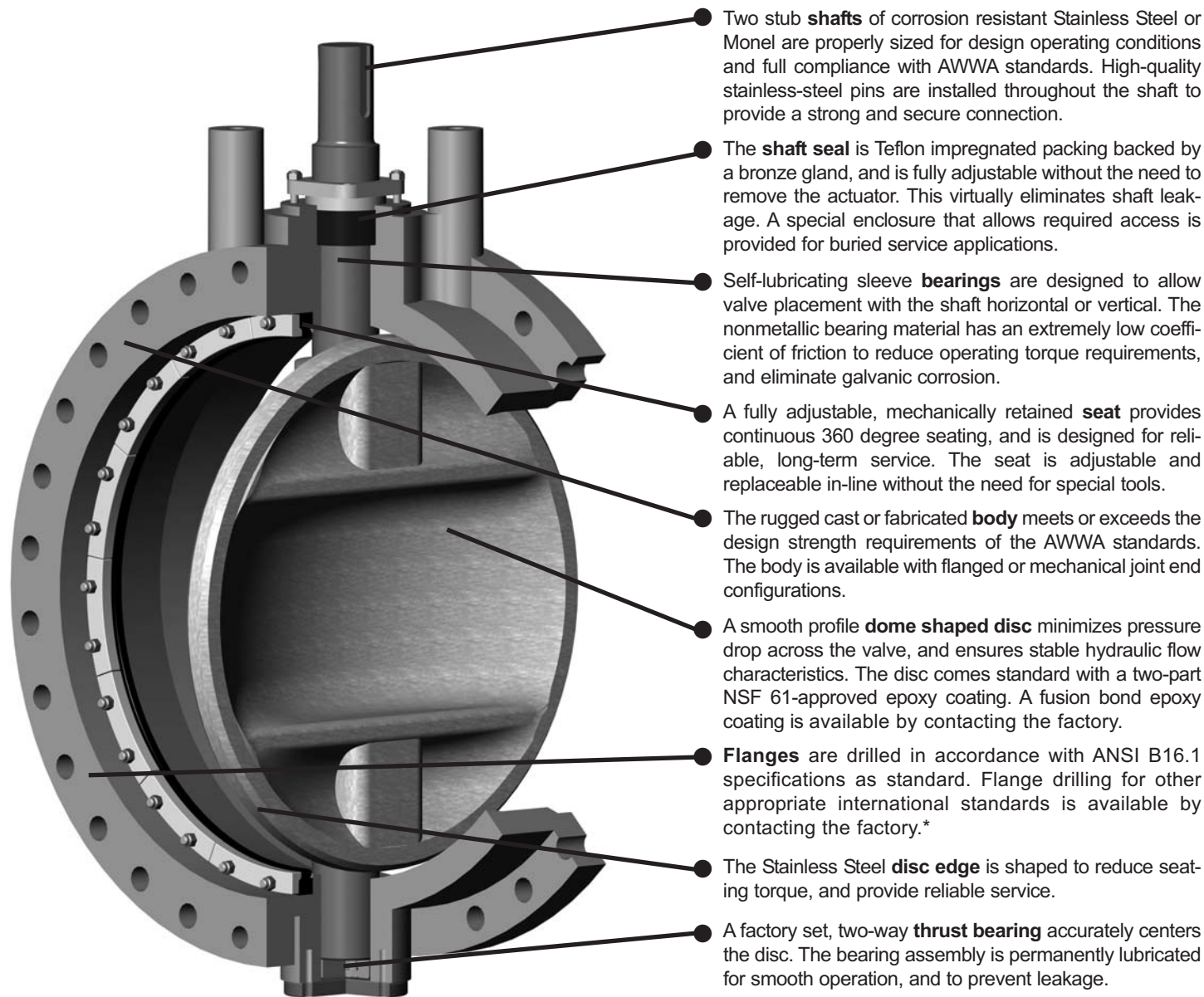

- Two stub **shafts** of corrosion resistant Stainless Steel or Monel are properly sized for design operating conditions and full compliance with AWWA standards. High-quality stainless-steel pins are installed throughout the shaft to provide a strong and secure connection.
- The **shaft seal** is Teflon impregnated packing backed by a bronze gland, and is fully adjustable without the need to remove the actuator. This virtually eliminates shaft leakage. A special enclosure that allows required access is provided for buried service applications.
- Self-lubricating sleeve **bearings** are designed to allow valve placement with the shaft horizontal or vertical. The nonmetallic bearing material has an extremely low coefficient of friction to reduce operating torque requirements, and eliminate galvanic corrosion.
- A fully adjustable, mechanically retained **seat** provides continuous 360 degree seating, and is designed for reliable, long-term service. The seat is adjustable and replaceable in-line without the need for special tools.
- The rugged cast or fabricated **body** meets or exceeds the design strength requirements of the AWWA standards. The body is available with flanged or mechanical joint end configurations.
- A smooth profile **dome shaped disc** minimizes pressure drop across the valve, and ensures stable hydraulic flow characteristics. The disc comes standard with a two-part NSF 61-approved epoxy coating. A fusion bond epoxy coating is available by contacting the factory.
- **Flanges** are drilled in accordance with ANSI B16.1 specifications as standard. Flange drilling for other appropriate international standards is available by contacting the factory.*
- The Stainless Steel **disc edge** is shaped to reduce seating torque, and provide reliable service.
- A factory set, two-way **thrust bearing** accurately centers the disc. The bearing assembly is permanently lubricated for smooth operation, and to prevent leakage.

MATERIALS

SIZES

24"-72" in AWWA Class 75, 150, 250 (meets or exceeds AWWA C504)
 Sizes 78" and above are AWWA compliant.

BODY

Cast Iron (ASTM A126, Class B)
 Ductile Iron (ATM A536, Grade 65-45-12)

SEAT

Buna-N; EPDM Optional

SHAFT

ASTM A276, Grade 304 or 316 Stainless Steel.
 Optional: Monel 17-4pH Stainless Steel on Class 250B

DISC

Ductile Iron (ASTM A536, Grade 65-45-12)
 w/ 316 Stainless Steel Edge

BEARINGS

316 Stainless Steel; TFE Lined

* Class 250B valves with AWWA Type "E" and "F" flanges are available. Please contact the factory.

- Series 47 valves fully comply w/ AWWA C504's latest edition.
- Series 47 valves have passed the proof of design tests of AWWA C504
- Consult factory for 75B shaft diameters.

- "Q" Dimension is the minimum allowable inside diameter at the centered body face to protect the disc sealing edge from damage when opening the valve.
- Consult factory for valve dimensions in sizes greater than 72" and mech. joint dims.

47 SERIES: Dimensional Data

K-FLO Model 47 (Flanged x Flanged, AWWA Class 150B)

Bare Shaft

Size in.	A	B in.	C in.	D in.	E	F	G	H	J in.	K in.	L in.	M in.	N in.	P in.	Q in.	Weight in lbs.
24	36	32	18 ¹ / ₂	29 ¹ / ₂	2 ¹ / ₈	8	7 ³ / ₈	3 ¹ / ₂	3	2 ³ / ₄	7 ¹ / ₁₆ X5 ⁵ / ₈ X2 ¹ / ₂	7 ¹ / ₂	3 ⁴ / ₁₆ -10 _{NC} X1 ¹ / ₄ DP	(4)1 ⁻¹ / ₄ -7 _{NC}	(16)1 ³ / ₈	740
30	46 ⁷ / ₈	38 ³ / ₄	25 ³ / ₈	36	2 ¹ / ₈	12	8 ³ / ₈	4 ¹ / ₂	3 ⁵ / ₈	3	1 ¹ / ₂ X3 ³ / ₄ X3 ¹ / ₂	11 ³ / ₄	1-8 _{NC} X1 ¹ / ₂ ZDP	(6)1 ⁻¹ / ₄ -7 _{NC}	(22)1 ³ / ₈	1650
36	54	46	28 ³ / ₄	42 ³ / ₄	2 ⁷ / ₁₆	12	11 ³ / ₈	4 ⁷ / ₈	4 ³ / ₈	3 ¹ / ₈	1 ¹ / ₂ X3 ³ / ₄ X3 ¹ / ₂	11 ³ / ₄	1-8 _{NC} X1 ¹ / ₂ ZDP	(6)1 ⁻¹ / ₂ -6 _{NC}	(26)1 ⁵ / ₈	2380
42	58 ⁷ / ₈	53	30 ¹⁵ / ₁₆	49 ¹ / ₂	2 ¹¹ / ₁₆	12	13 ¹³ / ₁₆	6 ⁵ / ₁₆	5	4	3 ⁴ / ₁₆ X1X5	11 ³ / ₄	1-8 _{NC} X1 ¹ / ₂ ZDP	(6)1 ⁻¹ / ₂ -6 _{NC}	(30)1 ⁵ / ₈	3260
48	65 ¹⁵ / ₁₆	59 ¹ / ₂	34 ³ / ₄	56	2 ³ / ₄	15	15 ⁷ / ₁₆	6 ⁵ / ₁₆	5 ⁵ / ₈	4	3 ⁴ / ₁₆ X1X5	16	1 ¹ / ₈ -7 _{NC} X2DP	(8)1 ⁻¹ / ₂ -6 _{NC}	(36)1 ⁵ / ₈	4490
54	75 ¹¹ / ₁₆	66 ¹ / ₄	40 ³ / ₁₆	62 ³ / ₄	3	15	18 ³ / ₈	6 ¹⁵ / ₁₆	6 ³ / ₄	5 ¹ / ₂	7 ¹ / ₈ X1 ¹ / ₄ X5 ³ / ₄	16	1 ¹ / ₈ -7 _{NC} X2DP	(8)1 ⁻³ / ₄ -5 _{NC}	(36)2	5970
60	82 ³ / ₄	73	43 ⁵ / ₁₆	69 ¹ / ₄	3 ³ / ₁₆	15	21 ¹ / ₁₆	6 ¹⁵ / ₁₆	7 ¹ / ₄	5 ¹ / ₂	7 ¹ / ₈ X1 ¹ / ₄ X5 ³ / ₄	16	1 ¹ / ₈ -7 _{NC} X2DP	(8)1 ⁻³ / ₄ -5 _{NC}	(44)2	7550
66	89 ⁷ / ₈	80	47	76	3 ³ / ₈	18	23 ³ / ₁₆	8	7 ³ / ₄	6	1X1 ¹ / ₂ X7	18 ³ / ₈	1 ¹ / ₄ -7 _{NC} X2 ¹ / ₄ DP	(8)1 ⁻³ / ₄ -5 _{NC}	(44)2	9920
72	97 ⁴ / ₁₆	86 ¹ / ₂	51 ¹ / ₁₆	82 ¹ / ₂	3 ⁹ / ₁₆	18	25 ¹³ / ₁₆	8 ³ / ₁₆	8 ¹ / ₂	6	1X1 ¹ / ₂ X6	18 ³ / ₈	1 ¹ / ₄ -7 _{NC} X2 ¹ / ₄ DP	(10)1 ⁻³ / ₄ -5 _{NC}	(50)2	12,050
78	101 ¹ / ₁₆	93	52 ¹³ / ₁₆	89	3 ³ / ₄	18	29	10 ⁷ / ₁₆	7 ¹ / ₄	7 ¹ / ₄	1 ¹ / ₂ X1 ³ / ₄ X9	18 ³ / ₈	1 ¹ / ₄ -7 _{NC} X2 ¹ / ₄ DP	(10)2-4 ⁻¹ / ₂ NC	(54)2 ¹ / ₄	12,200
84	108 ³ / ₈	99 ³ / ₄	56 ⁷ / ₁₆	95 ¹ / ₂	3 ¹⁵ / ₁₆	18	32	9 ⁷ / ₁₆	7 ³ / ₄	7 ¹ / ₄	1 ¹ / ₂ X1 ³ / ₄ X8	18 ³ / ₈	1 ¹ / ₄ -7 _{NC} X2 ¹ / ₄ DP	(8)2-4 ⁻¹ / ₂ NC	(56)2 ¹ / ₄	16,700
90	116 ³ / ₁₆	106 ¹ / ₂	60 ⁷ / ₁₆	102	4 ³ / ₁₆	21	33 ¹⁵ / ₁₆	10 ³ / ₁₆	8 ¹ / ₂	7 ¹ / ₂	1 ¹ / ₂ X1 ³ / ₄ X9	23	1 ¹ / ₂ -6 _{NC} X2 ¹ / ₂ ZDP	(20)2 ⁻¹ / ₄ -4 ⁻¹ / ₂ NC	(48)2 ¹ / ₂	22,250
96	122 ⁵ / ₈	113 ¹ / ₄	63 ⁵ / ₈	108 ¹ / ₂	4 ¹ / ₄	21	36 ³ / ₈	12 ¹ / ₄	9	9	1 ¹ / ₂ X2X10	23	1 ¹ / ₂ -6 _{NC} X2 ¹ / ₂ ZDP	(24)2 ⁻¹ / ₄ -4 ⁻¹ / ₂ NC	(44)2 ¹ / ₂	26,000

K-FLO Model 47 (Flanged x Flanged, AWWA Class 250B)

Bare Shaft

Size in.	A	B in.	C in.	D in.	E in.	F in.	G in.	H in.	J in.	K in.	L in.	M in.	N in.	P in.	Q in.	WT. lbs
24	39 ¹ / ₂	36	20 ¹ / ₈	32	2 ³ / ₄	12	5 ⁷ / ₁₆	3 ¹ / ₂	3	2 ³ / ₄	7 ¹ / ₁₆ X5 ⁵ / ₈ X2 ¹ / ₂	7 ¹ / ₂	3 ⁴ / ₁₆ -10 _{NC} X1 ¹ / ₄ DP	(4)1 ⁻¹ / ₂ -6 _{NC}	(20)1 ⁵ / ₈	990
30	50 ⁷ / ₈	43	27 ¹ / ₄	39 ¹ / ₄	3 ¹ / ₈	12	8 ³ / ₈	5 ¹ / ₂	3 ⁵ / ₈	3 ¹ / ₈	1 ¹ / ₂ X3 ³ / ₄ X3 ¹ / ₂	11 ³ / ₄	1-8 _{NC} X1 ¹ / ₂ DP	(6)1 ⁻³ / ₄ -5 _{NC}	(22)2	1950
36	57 ¹⁵ / ₁₆	50	30 ⁵ / ₈	46	3 ³ / ₈	15	9 ⁷ / ₈	6 ⁷ / ₈	4 ³ / ₈	4	1 ¹ / ₂ X3 ³ / ₄ X3 ¹ / ₂	16	1 ¹ / ₈ -7 _{NC} X2DP	(6)2-4 ⁻¹ / ₂ NC	(26)2 ¹ / ₄	3000
42	62 ¹¹ / ₁₆	57	32 ³ / ₄	52 ³ / ₄	3 ¹¹ / ₁₆	15	12 ³ / ₈	7 ¹ / ₂	5	5	3 ⁴ / ₁₆ X1 ¹ / ₄ X5	16	1 ¹ / ₈ -7 _{NC} X2DP	(8)2-4 ⁻¹ / ₂ NC	(28)2 ¹ / ₄	4175
48	70 ³ / ₄	65	36 ³ / ₄	60 ³ / ₄	4 ¹ / ₁₆	15	15 ⁷ / ₁₆	8	5 ⁵ / ₈	5 ¹ / ₂	7 ¹ / ₈ X1 ¹ / ₄ X6	16	1 ¹ / ₈ -7 _{NC} X2DP	(8)2-4 ⁻¹ / ₂ NC	(32)2 ¹ / ₄	5475

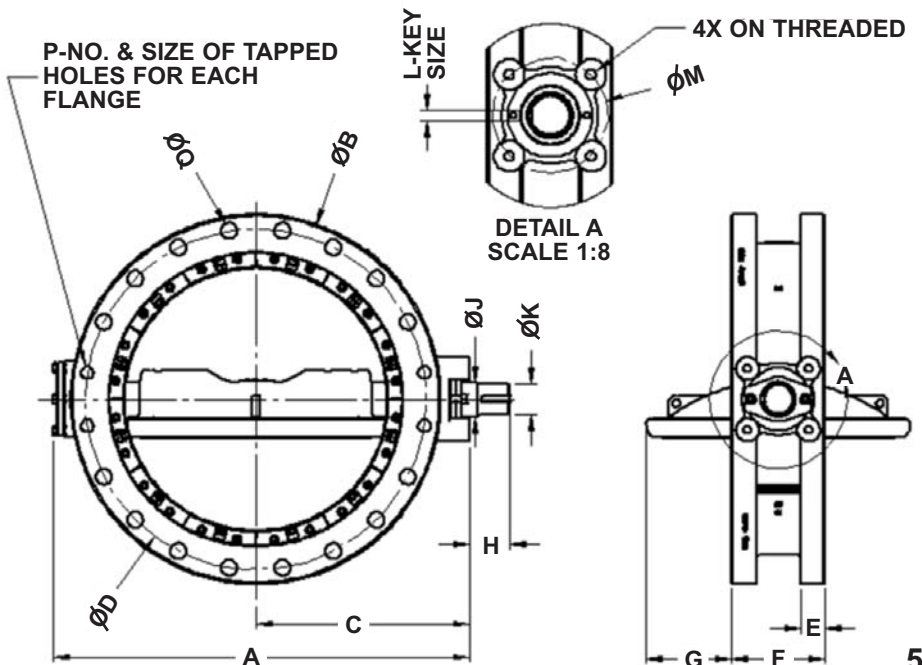
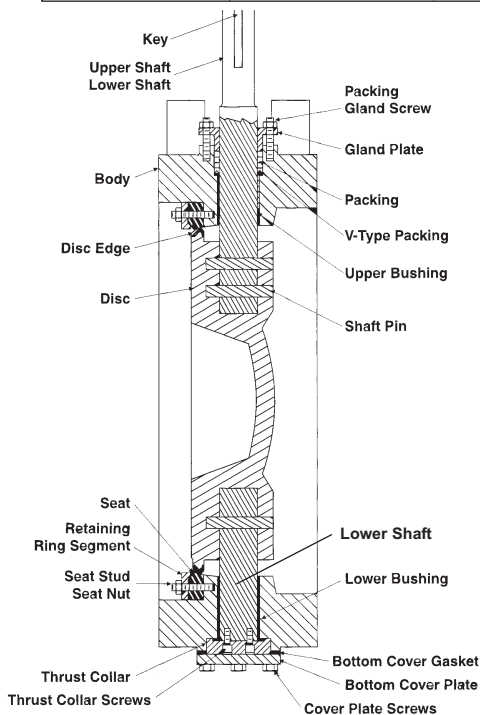

CV VALUES

What is Cv and Why is it Important?

The flow characteristic of a given valve is defined by the valve's Cv value. Cv is defined as the maximum flow (expressed in gallons per minute, or gpm) of water at 60 degrees F, which produces a 1 psig pressure drop across the valve.



Mathematical Formula for Cv

The mathematical formula for Cv (flow coefficient) is:

$$Cv = Q/\sqrt{\Delta P}$$

Where: Q = Flow rate in gpm;
 ΔP = Pressure Drop across the valve in psig.

Cv can also be used for fluids other than water by using the following formula:

$$Cv = Q/\sqrt{(\Delta P/G)}$$

Where G = Specific gravity of the fluid (water=1.0)
 ΔP = Pressure Drop across the valve in psig.

For example, if the valve must pass water at a flow rate of 300gpm, and the maximum allowable pressure drop is 3psig, the Cv of the valve must be equal to or greater than 173.2.

$$Cv = 300\text{gpm}/\sqrt{3\text{psig}} = 173.2$$

Cv VALUES



MODEL 47

SIZE	Cv (gpm/ $\sqrt{\text{psi}}$)
24"	27889
30"	42200
36"	62060
42"	78930
48"	107930
54"	131350
60"	169220
66"	212430
72"	255880

Cv VALUES: MODEL 504



SIZE	Cv (gpm/ $\sqrt{\text{psi}}$)
3"	228
4"	463
6"	1069
8"	2372
10"	4380
12"	6515
14"	9574
16"	13356
18"	16898
20"	20421

TNA TRAVELING NUT ACTUATOR

K-Flo provides its 20" and smaller 500 series AWWA Butterfly Valves with the TNA series Traveling Nut Actuator as the standard manual operator. The TNA is designed to exceed the rigorous requirements of AWWA specifications. Unlike other market options like small-sized worm gears, the TNA offers rugged construction and clear design benefits. One key benefit is the variable torque curve generated through the operation stroke. Differing from a worm gear's constant torque production, the TNA traveling nut operator allows the valve to open and close at slower speeds, reducing the potential for line surge from faster valve operation.

The TNA also has many other helpful features including four standard 90-degree key locations to choose from when connecting the operator to the valve. This provides orientation flexibility should the need arise to re-position the actuator due to space confinements.

Available in both Above-Ground (with integral position indicator) and Buried Service configurations.

HOUSING/COVER
Cast Iron ASTM A126

STEM (INPUT SHAFT)
4140 Steel ASTM 434

YOKE
Ductile Iron ASTM A536

CROSSHEAD
4140 Steel, ASTM 434

KEY
4140 Steel, ASTM 434

SQUARE NUT (STOP)
4140 Steel ASTM 434

GUIDE RAIL
4140 Steel ASTM 434

SHAFT COLLAR
4140 Steel ASTM 434

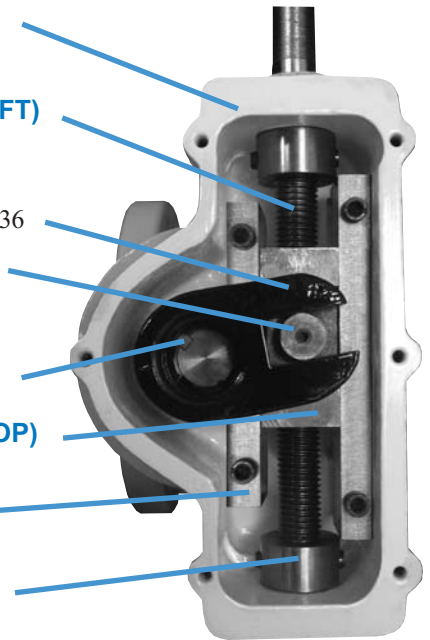

TNA ACTUATOR CHARACTERISTICS

As a butterfly valve disc approaches the closed position, the inherent design characteristics of the traveling nut type actuator cause the disc travel to slow down in relation to the turning of the operating nut or handwheel. This characteristic helps reduce the effects of water hammer caused by sudden valve closure.

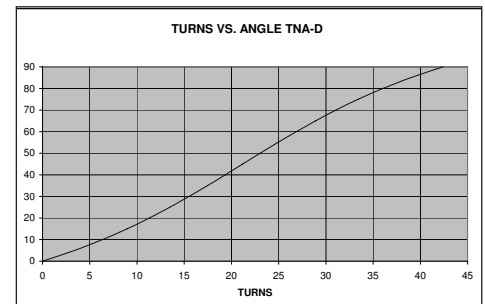
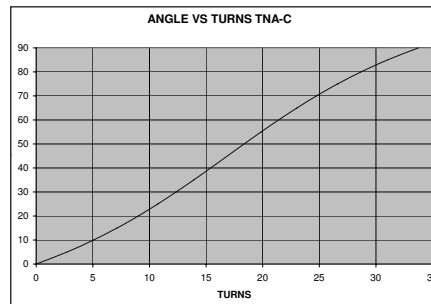
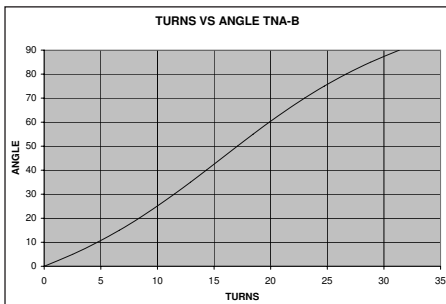

ADDITIONAL ACTUATOR OPTIONS AND EXTENSIONS

K-Flo works with all major actuator manufacturers, and we are capable of mounting any actuators--manual, electric or pneumatic--that our customers may specify. We've listed some of the more traditional actuator options below, and invite you to call us at our factory with any additional requests or questions that you may have.

MANUAL ACTUATION OPTIONS

Above Ground Manual Operators

- Lever operators with ten position selector plate. Available for valve sizes 3" thru 8".

- Handwheel and chainwheel gear operators for all valve sizes. These operators come standard with dial position indicators.

Buried and Submerged Service Gear Operators

- Buried and submerged gear operators are available for all valve sizes. These operators come standard with a 2" AWWA nut and sealed gear housing.

For gears continuously submerged at depths greater than 10 feet, please indicate specifications. This will assure the end user that a gear for the intended service is provided.

POWER OPERATORS

Cylinder Operators

- Cylinder operators are available in pneumatic or hydraulic options. They are available as double acting operators or spring return for a specific failure mode (fail open or fail close). All cylinder accessories are available for on/off or modulating service.

Electric Motor Operators

- Electric motor operators are available in numerous configurations for varied service conditions. Control options for on/off service and modulating service are available.

SUGGESTED K-FLO SPECIFICATIONS

1.00 GENERAL

1.01 WORK INCLUDED

- Furnish labor, materials, equipment and incidentals necessary to install butterfly valves.

1.02 QUALITY ASSURANCE

A. ACCEPTABLE MANUFACTURERS

1. Crispin-Kflo (Series 500 for 3" to 20" and Series 47 for 24" and larger)
2. Engineer pre-approved equal

B. EXPERIENCE REQUIREMENTS

The Manufacturer shall have had a successful experience in manufacturing tight closing Buna-N or other acceptable synthetic rubber-seated butterfly valves for this type service in the size indicated. The Manufacturer shall have at least 10 years experience in the manufacture of valves. All butterfly valves of the same type shall be the product of one Manufacturer. All materials used shall be new, of high grade, and with properties best suited to the working environment.

C. MANUFACTURER'S REPRESENTATIVE FOR STARTUP AND TESTING

The Valve Vendor or Manufacturer shall provide the services of a competent Manufacturer's representative for a sufficient period of time as required to insure proper adjustment, installation, and operation of the valve.

1.03 SUBMITTALS

A. Certificate of Compliance or complete list of all deviation from the drawings and specifications.

B. Submit installation and assembly drawings complete with seat installation details, showing the manufacturer's dimensions, weights, and loadings.

C. Submit any and all electrical schematic, wiring diagrams, and interconnection diagrams showing wiring, controls, interlocks, and terminals. Label each terminal and wire showing which control or electrical power wire connects to which terminal. Submit manufacturer's catalog data for electrical equipment and enclosures.

D. Submit flow coefficient, Cv, and maximum pressure drop at rated flow rate for each valve size used.

E. Submit manufacturer's installation instructions and certification.

F. Provide O&M manual and spare parts list with descriptive literature, including a cross-section view of valve and all operators, which indicate materials of construction, weights, principal dimensions and other important details.

2.00 PRODUCTS

2.01 BUTTERFLY VALVES

A. All butterfly valves shall be of the tight-closing, rubber-seated type, conforming to the design standards of ANSI/AWWA C504 latest revision, except where noted herein. Valves shall be bubble-tight at the rated pressure in either direction and shall be suitable for throttling service and/or operation after long periods of inactivity. Maximum operating non-shock shut-off pressure and maximum operating non-shock line pressure is 150 psi. Each valve shall be performance and leak tested as specified in AWWA C504 revised as follows: In addition to the testing requirements of AWWA C504, each butterfly valve shall be thoroughly cleaned and opened at least three (3) times prior to testing.

B. All items shall have the name or symbol of the maker, the nominal size, date of manufacture, and the working pressure for which they are designed, cast, stamped, or permanently marked on the body.

C. Butterfly valves shall be Class 150B, unless otherwise indicated and of the flanged short body design. The valve bodies shall be constructed of cast iron ASTM A-126, Class B or ductile iron in accordance with ASTM A-536 with ANSI B16.1 flange drilling or for mechanical joint ends shall conform to ANSI/AWWA C111/A21.11 standard. Flanges shall conform to AWWA Class D standards.

D. Discs for valve sizes 3" – 20" shall be of the concentric design. Valve discs shall be constructed of 316 stainless steel for sizes 3" to 8" and epoxy coated ductile iron ASTM A-536 for sizes 10" to 20". Discs for valve sizes 24" and larger shall be of the offset design to provide a full 360 degree seating surface and shall be constructed from epoxy coated ductile iron ASTM A-536. Valve disc shall have a 316 stainless steel seating edge. Valve disc shall seat at 90 degrees to the access of the pipe and shall require no torque to hold it in the closed position.

E. Valves 3" – 20" shall have a one piece through shaft constructed of stainless steel ASTM A-276, grade 304, corresponding to the requirements of AWWA C504, latest revision. The shaft shall be fastened to the disc by means of a threaded disc pin providing a positive leak proof connection of the shaft to the disc. Valves 24" and larger shall have stub shafts of stainless steel ASTM A-276, grade 304, corresponding to the design requirements of AWWA C504, latest revision. The shafts shall be fastened to the disc by straight pins that provide a .005 interference fit. The use of taper pins for the shaft/disc connection is not acceptable.

F. The resilient seat shall be Buna-N for valves 3" – 20" and shall be simultaneously bonded and vulcanized to body of the valve. All interior surfaces

in contact with water, excluding stainless steel and disc, shall be completely rubber lined. Seats for valves 3"–20" shall be designed so that they will require no internal adjustment or maintenance to seat against a pressure differential of 150 psi on either side of the valve. The resilient seat shall be Buna-N for valves 24" and larger and shall be mechanically retained in the body by means of 316 stainless steel attachment hardware. The seat shall be fully adjustable and replaceable in the field with the use of a standard wrench. No special tools shall be required. Valve seat designs in the body that require the use of epoxy to retain the seat or fillers to increase seat compression are not considered mechanically retained, field replaceable, or adjustable, and will not be accepted. Valves with seat designs that are located on the disc will not be acceptable.

G. All bearings shall be of the self-lubricating, corrosion-resistant, sleeve type. Bearings shall be designed for horizontal and/or vertical shaft loading. The valve assembly shall be furnished with a factory set two-way thrust bearing designed to center the valve disc in the valve seat at all times.

H. Shaft packing shall be of the V-type, self-adjusting type and suitable for pressure and vacuum service. Valves 24" and larger shall be designed with pull down packing which shall be fully adjustable and replaceable without removing the actuator. The packing shall be PTFE, interlocking braid, self compensating type. Stuffing boxes for pull down packing shall have a depth sufficient to accept at least four (4) rings of self-compensating type packing specifically selected for the operating pressure to be encountered.

I. The Manufacturer shall certify that the butterfly valves are capable of operating in continuous duty service under the specified pressures and flow conditions.

J. The interior of valves 3" – 20" shall be completely rubber lined. The valve disc shall either be entirely 316 stainless steel or be ductile iron with epoxy coating from an AWWA NSF-61 coating system. The use of liquid epoxy on body interior surfaces shall not be allowed. Valves 24" and larger: the interior of the valve body and the exterior of the valve disc shall be cleaned and sandblasted and lining shall be applied as per the Manufacturer's instructions. The lining material shall be in compliance with ANSI/NSF Standard 61, for contact with potable water. The lining material shall be "Pota-Pox" as manufactured by Tnemec, or equal. The interior lining shall be applied in a minimum of two coats, at 4–5 mils per coat; the total dry thickness shall be 8 – 10 mils.

K. The exterior surfaces shall be cleaned and sandblasted and coating shall be applied in accordance with the Manufacturer's instructions. Surface face cleanliness shall be inspected and any contaminants on the surface shall be removed prior to the coating operations. The coating material shall be "Pota-Pox" as manufactured by Tnemec, or equal. The coating material shall be applied in a minimum of two coats, at 4–5 mils per coat; the total dry thickness shall be 8– 10 mils.

3.00 EXECUTION

3.01 INSTALLATION

A. Valve installation shall be in strict accordance with the Manufacturer's printed recommendations, and the Contract Documents. Valve shaft shall be truly vertical or horizontal as indicated.

B. Four (4) copies of Final Operations and Maintenance Manuals are to be provided. The manuals shall include but not be limited to the following: installations and adjustment instructions; maintenance procedures and operation parameters; wiring diagrams; control diagrams; control sequence and instructions; lubrication schedule, including type, grade, temperature range, and frequency; diagrams and illustrations; test procedures, performance data; and parts list.

3.02 FIELD QUALITY CONTROL

A. Upon completion of installation of the butterfly valves an acceptance test shall be conducted to verify the satisfactory operation of the valves. The valves must perform in a manner acceptable to the Engineer before final acceptance will be made by the owner.

3.03 WARRANTY

A. The manufacturer warrants the workmanship and materials to be free from defect for a period of one (1) year from the date of shipment from the factory. The manufacturer shall replace any parts deemed defective during the said time period, provided that the product has been properly applied and used for the purpose intended. The manufacturer must be notified of the alleged defect and provided with the proper data as to the application. The manufacturer at its discretion will repair or replace the product, F.O.B. factory. The manufacturer shall not be liable to the buyer or others for any consequential or incidental damage. The unit shall not be disassembled in any way by the buyer, unless written permission and instruction is provided by the manufacturer—otherwise the warranty is void. The buyer agrees that the manufacturer shall not be liable for any loss, cost, expenses, or damages from the product, its uses, installation or replacement, instructions, labeling, technical data, description of the product, its uses or warnings or lack of any of the foregoing. No other warranties, written or oral, expressed or implied, shall apply.