

**Class 125 • Bolted Bonnet • OS&Y • Bronze Trim • Flanged Ends**

**Figure 465 1/2**  
Flanged with Bronze Trim

**Size Range:**  
2 through 36 inches

**Working Pressures Non-Shock**  
2" – 12"

125 psi Steam, Basic Rating  
200 psi Cold Working Pressure

14" – 36"  
100 psi Steam, Basic Rating  
150 psi Cold Working Pressure

**Features**

- Tapered Solid Wedge Disc
- Body Guide Ribs
- Renewable Bronze Seat Rings
- Stem provided with ACME Double Threads for 24" and smaller valves.
- Non-Asbestos Packing and Gaskets
- MSS SP-70 Type 1 and MSS SP-25
- ASME B16.10, ASME B16.1
- Valves can be equipped with by-passes when specified.

For more detailed features, refer to page 7.

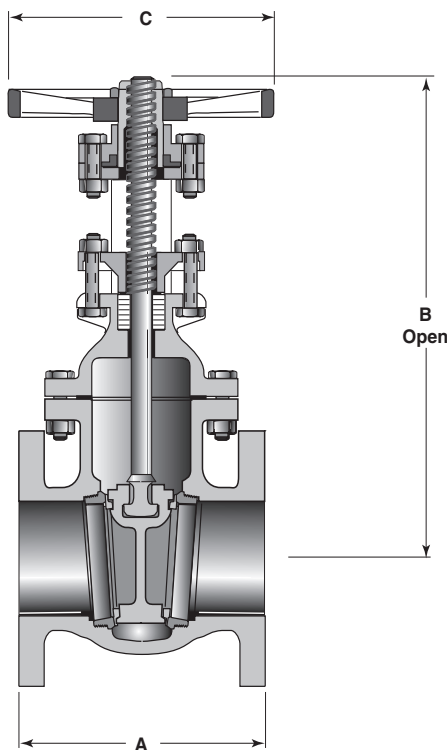

**Principal Parts & Materials**

Fig. No.	Size	Stem	Seating	End Conn.
465 1/2	2" - 36"	Bronze	Bronze	Flanged

**Dimensions and Weights**

Inches (millimeters) - pounds (kilograms)

Valves	2 (50)	2 1/2 (65)	3 (80)	4 (100)	5 (125)	6 (150)	8 (200)	10 (250)	12 (300)	14 (350)	16 (400)	18 (450)	20 (500)	24 (600)	30 (750)	36 (900)
A	7.00 (178)	7.50 (191)	8.00 (203)	9.00 (229)	10.00 (254)	10.50 (267)	11.50 (292)	13.00 (330)	14.00 (356)	15.00 (381)	16.00 (406)	17.00 (432)	18.00 (457)	20.00 (508)	24.00 (610)	28.00 (711)
B	14.75 (375)	16.06 (408)	17.38 (441)	21.44 (545)	25.81 (656)	30.31 (770)	37.75 (959)	49.41 (1255)	56.81 (1443)	64.88 (1648)	75.25 (1911)	82.00 (2083)	90.62 (2302)	105.38 (2677)	160.25 (4070)	192.69 (4894)
C	8.00 (203)	8.00 (203)	8.00 (203)	10.00 (254)	10.00 (254)	12.00 (305)	14.00 (356)	18.00 (457)	18.00 (457)	20.00 (508)	22.00 (559)	22.00 (559)	24.00 (610)	30.00 (762)	30.00 (762)	30.00 (762)
Wt.	33 (15)	47 (21)	58 (26)	97 (44)	135 (61)	162 (73)	280 (126)	502 (228)	670 (304)	1093 (497)	1425 (646)	1738 (789)	2085 (946)	3183 (1445)	5795 (2629)	7622 (3457)