

Class 150 • Union Bonnet • Rising Stem • Threaded Ends

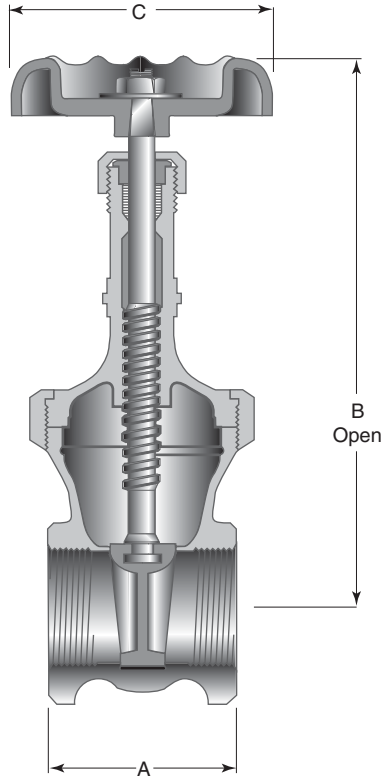

Features

- Rising Stem
- Union Bonnet
- Solid Wedge Disc
- Threaded Ends
- Full Ports
- Back Seat
- Integral Bronze Seat
- MSS SP-80, Type 2

For more detailed features, refer to page 18.

Figure 431UB

Size Range:

1/4" through 3"

Working Pressures Non-Shock:

150 psi Steam, Basic Rating

300 Cold Working Pressure

Principal Parts & Materials

Part	Size	Material	ASTM
Body & Union bonnet	All	Bronze	B62 alloy C83600
Disc	All	Bronze	B62 alloy C83600
Stem	1/4"-2"	Bronze	B505 alloy C83600
Stem	2 1/2"-3"	Bronze	B371 alloy C69400

Dimensions and Weights

Inches (millimeters) - pounds (kilograms)

	1/4	3/8	1/2	3/4	1	1 1/4	1 1/2	2	2 1/2	3
	(6)	(10)	(15)	(20)	(25)	(32)	(40)	(50)	(65)	(80)
A	1.64 (42)	1.64 (42)	2.03 (52)	2.14 (54)	2.46 (62)	2.78 (71)	2.85 (72)	3.25 (83)	4.24 (108)	4.63 (118)
B	4.84 (123)	4.84 (123)	4.98 (126)	6.29 (160)	7.39 (188)	8.57 (218)	9.68 (246)	11.89 (302)	14.86 (377)	17.02 (432)
C	2.06 (52)	2.06 (52)	2.08 (53)	2.57 (65)	2.76 (70)	3.08 (78)	3.64 (92)	4.00 (102)	5.24 (133)	5.24 (133)
WTS.	0.90 (0.41)	0.90 (0.39)	0.90 (0.41)	1.50 (0.68)	2.40 (1.07)	3.60 (1.63)	4.90 (2.22)	7.50 (3.40)	14.00 (6.35)	20.70 (9.37)