

Figure 431

# Bronze Gate Valve



**Class 150 • Threaded Bonnet • Rising Stem • Threaded Ends**

**Figure 431**

Solid Wedge Disc

**Size Range:**

¼" through 3"

**Working Pressures Non-Shock:**

150 psi Steam, Basic Rating

300 psi Cold Working Pressure

**Features**

- Rising Stem
- Screwed Bonnet
- Threaded Ends
- Full Ports
- Back Seat
- Integral Bronze Seat
- MSS SP-80, Type 2

For more detailed features, refer to page 18.

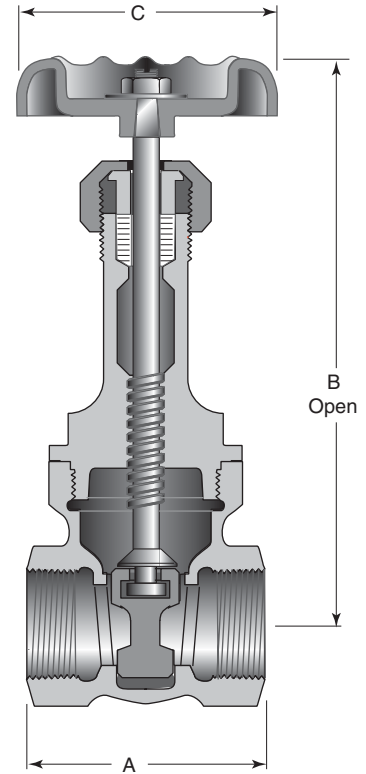

**Principal Parts & Materials**

Part	Size	Material	ASTM
Body & bonnet	All	Bronze	B62 alloy C83600
Disc	All	Bronze	B62 alloy C83600
Stem	½"-2"	Bronze	B505 alloy C83600
Stem	¼"-¾", 2 ½"-3"	Bronze	B371 alloy C69400

**Dimensions and Weights**

Inches (millimeters) - pounds (kilograms)

	¼ (6)	⅜ (10)	½ (15)	¾ (20)	1 (25)	1 ¼ (32)	1 ½ (40)	2 (50)	2 ½ (65)	3 (80)
A	1.80 (46)	1.68 (43)	2.02 (51)	2.14 (54)	2.46 (62)	2.77 (70)	2.85 (72)	3.25 (83)	4.25 (108)	4.61 (117)
B	4.78 (121)	4.93 (125)	4.98 (127)	6.28 (160)	7.44 (189)	8.49 (216)	9.77 (248)	11.98 (304)	14.93 (379)	16.83 (427)
C	1.77 (45)	2.05 (52)	2.08 (53)	2.57 (65)	2.76 (70)	3.08 (78)	3.65 (93)	4.06 (103)	5.26 (134)	5.26 (134)
WTS.	0.80 (0.36)	0.80 (0.36)	0.90 (0.39)	1.40 (0.64)	2.00 (0.91)	3.30 (1.47)	4.20 (1.91)	6.70 (3.02)	12.80 (5.81)	18.50 (8.39)