

Figure 373

# Iron Body Swing Check Valve

CRANE

**Class 125 • Bolted Cap • Bronze Trim • Flanged Ends**

Figure 373

Flanged with Bronze Trim

**Size Range:**

2 through 24 inches

**Working Pressures Non-Shock**

2"-12"

125 psi Steam, Basic Rating

200 psi Cold Working Pressure

14"-24"

100 psi Steam, Basic Rating

150 psi Cold Working Pressure

**Features**

- Design prohibits galling or scoring of seating surfaces because the disc meets the flat seat squarely on closing with no rubbing action
- Replaceable Bronze Seat Rings
- Bronze Hinges in 6" and smaller, ductile iron in larger sizes
- Large Bolted-on Cover
- Solid Bronze Disc 6" and smaller, Bronze Faced Cast Iron on larger sizes
- Replaceable Brass Hinge Pins
- ASME B16.1, MSS SP-71 Type 1 and MSS SP-25
- ASME B16.10 - 14" and smaller

For more detailed features, refer to page 28.

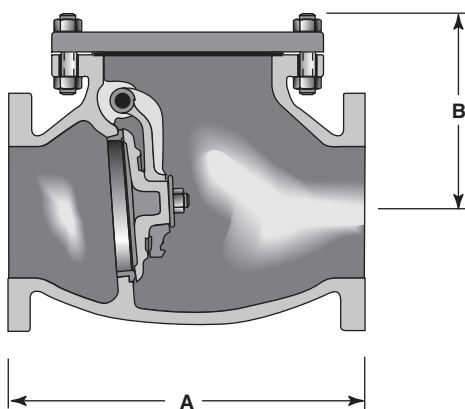

**Principal Parts & Materials**

Fig. No.	Size	Seating	End Conn.
373	2" - 24"	Bronze	Flanged

**Dimensions and Weights**

Inches (millimeters) - pounds (kilograms)

Valves	2 (50)	2 ½ (65)	3 (80)	4 (100)	5 (125)	6 (150)	8 (200)	10 (250)	12 (300)	14 (350)	16 (400)	18 (450)	20 (500)	24 (600)
A	8.00 (203)	8.50 (216)	9.50 (241)	11.50 (292)	13.00 (330)	14.00 (356)	19.50 (495)	24.50 (622)	27.50 (699)	31.00 (787)	36.00 (914)	36.00 (914)	40.00 (1067)	48.00 (1169)
B	4.50 (114)	5.38 (137)	5.88 (149)	6.62 (168)	7.75 (197)	8.25 (210)	10.25 (260)	12.00 (305)	13.75 (349)	15.75 (400)	17.25 (438)	19.00 (482)	21.87 (555)	24.43 (620)
Wt.	25 (11)	34 (15)	44 (20)	74 (33)	103 (47)	127 (58)	230 (104)	440 (200)	660 (299)	794 (360)	1020 (462)	1304 (591)	1771 (803)	2630 (1192)