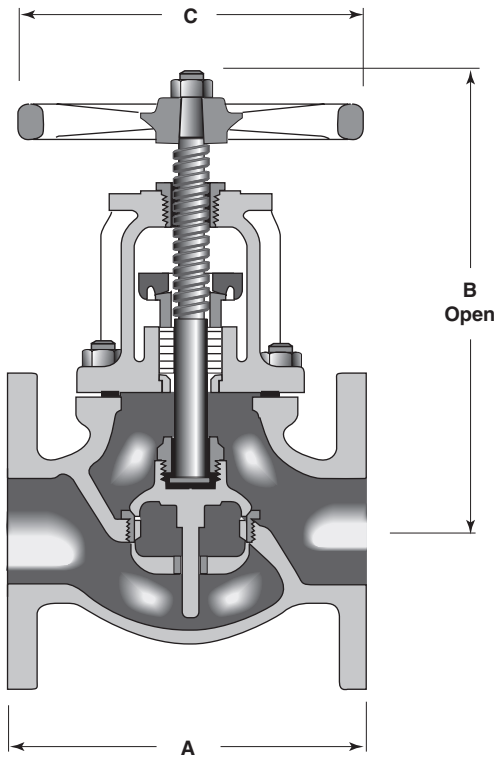

Figure 351

# Iron Body Globe Valve



**Class 125 • Bolted Bonnet • OS&Y • Bronze Trim • Flanged Ends**



**Figure 351**  
Flanged with Bronze Trim  
**Size Range:**  
2 through 10 inches

**Working Pressures Non-Shock**  
125 psi Steam, Basic Rating  
200 psi Cold Working Pressure

### Features

- Integral Yoke Bonnet with upper and lower bronze bushing provides for centering of internal parts
- Non Galling Two-Piece Packing Gland
- Valves are provided with a Back Seat
- Renewable - Re grindable Screwed-in Seat Ring
- Bottom Guided Disc
- Manganese Bronze Stem
- Non-Asbestos Packing & Gasket
- Solid Bronze Disc 6" and smaller
- ASME B16.1, ASME B16.10
- MSS SP-85 Type 1 and MSS SP-25

For more detailed features, refer to page 23.

### Principal Parts & Materials

Fig. No.	Size	Stem	Seating	End Conn.
351	2" - 10"	Bronze	Bronze	Flanged

### Dimensions and Weights

Inches (millimeters) - pounds (kilograms)

Valves	2 (50)	2 ½ (65)	3 (80)	4 (100)	5 (125)	6 (150)	8 (200)	10 (250)
A	8.00 (203)	8.50 (216)	9.50 (241)	11.50 (292)	13.00 (330)	14.00 (356)	19.50 (495)	24.50 (622)
B	11.12 (282)	11.50 (292)	13.25 (337)	15.50 (394)	17.50 (445)	19.50 (495)	25.00 (635)	30.50 (775)
C	8.00 (203)	8.00 (203)	9.00 (229)	10.00 (254)	10.00 (254)	12.00 (305)	16.00 (406)	18.00 (457)
Wt.	34 (15)	40 (18)	57 (26)	95 (43)	126 (57)	176 (80)	344 (156)	570 (259)