

Class 250 • Bolted Bonnet • OS&Y • Bronze Trim • Flanged Ends

Figure 28E

Flanged, Y-Pattern with Bolted Bonnet Straightway

Size Range:

2-½ through 10 inches

Working Pressures Non-Shock

250 psi Steam, Basic Rating

500 psi Cold Working Pressure

Features

- For installation between boilers supplying the same steam header, and positioned with pressure under the disc. Straightway is for horizontal or vertical line with upward flow. Angle valves are for "horizontal-downward" or "upward-horizontal" flow.
- These valves will perform the four following important functions:
 1. Act as an automatic-non return valve applied as a containment device to prevent gross backflow of steam from main header to boiler in case the boiler fails.
 2. Assist in cutting out boiler, when ceasing to fire. In this case, valve disc automatically closes to restrict backflow of steam to the boiler.
 3. Assist in returning boiler after a shut-down.
 4. Restricts backflow of steam from header into boiler which has been shut down and accidentally opened. The check valve feature should not be relied upon for primary shut-off.
- Cylindrical shaped disc is the only pressure-actuated part, light in weight with

ample guiding surface. It is specially designed to produce a maximum lift at minimum velocities. There are no wing guides to cause "spinning" with resultant rapid wear.

- Long throttling lip on disc retards flow when seating position is approached. Disc chattering is prevented and wire-drawing of seating surfaces is reduced.
- Flat Seats, accurately machined, facilitate true seating.
- Removable cast iron liner guides the disc throughout its full travel. Being entirely independent of the body, it is not subject to distortion by expansion strains.
- Piston Ring 6" and larger adds to dashpot's ability to avoid rapid disc movements. Where pulsations are extremely severe, two rings can be installed.
- Dashpot is self-contained in the liner. It provides an effective cushion for the disc to prevent pipe line vibrations or hammering on the seat at low velocities or on pulsating loads.
- Flanges conform to ASME B16.1. Flanges have 1/16" raised face with concentric grooves.
- The body has integral bosses for drain connections. The bosses are tapped and plugged.
- Determining the proper valve size needed is important. The size of a stop check valve should be based on the boiler capacity and steam flow through the valve, rather than on the size of the boiler outlet or existing piping.
- Valves require a minimum of 50psi differential pressure to seat the valve.

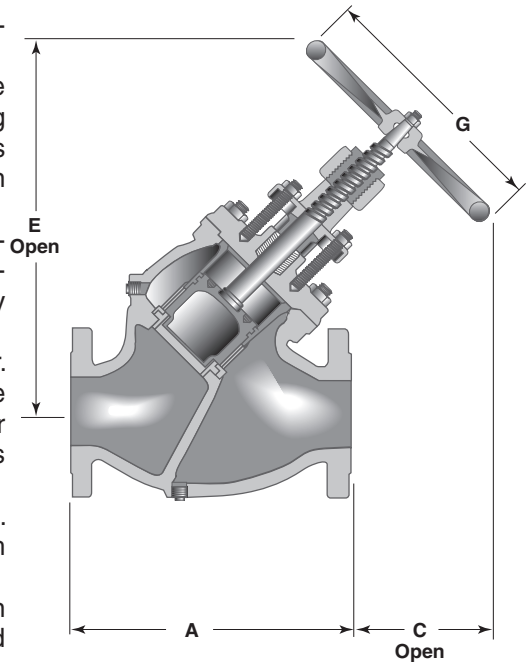

Dimensions and Weights

Inches (millimeters) - pounds (kilograms)

Valves	2 ½ (65)	3 (80)	4 (100)	5 (125)	6 (150)	8 (200)	10 (250)
A	13.00 (330)	14.75 (375)	17.00 (432)	19.00 (483)	21.50 (546)	26.00 (660)	30.00 (762)
C*	5.00 (127)	7.25 (184)	7.75 (197)	10.50 (267)	11.75 (298)	16.25 (413)	17.75 (451)
E*	15.75 (400)	19.75 (502)	21.75 (552)	25.75 (654)	29.25 (743)	36.75 (933)	41.75 (1060)
G	9.00 (229)	10.00 (254)	10.00 (254)	14.00 (356)	16.00 (406)	20.00 (508)	20.00 (508)
Wt.	103 (47)	140 (64)	226 (103)	307 (139)	420 (191)	737 (335)	1250 (568)