

**Class 250 • Bolted Bonnet • OS&Y • Bronze Trim • Flanged Ends**

### Features

- Integral Yoke Bonnet
- Non Galling Two-Piece Packing Gland
- Bronze Seat Ring, ASTM B61
- Disc Stem Ring
- Manganese Bronze Stem
- Non-Asbestos Packing and Gasket
- Valves are provided with a Back Seat
- Renewable - Re grindable, Screwed-in Seat Ring
- Bottom Guided Disc
- Solid Bronze Disc, ASTM B61 - 3" and smaller. 4" and larger cast iron with bronze facing, ASTM B61
- ASME B16.1, ASME B16.10
- MSS SP-85 Type 1 and MSS SP-25

For more detailed features, refer to page 23.

### Figure 21E

Flanged - Bronze Trim

#### Size Range:

2 through 8 inches

#### Working Pressures Non-Shock

250 psi Steam, Basic Rating

500 psi Cold Working Pressure

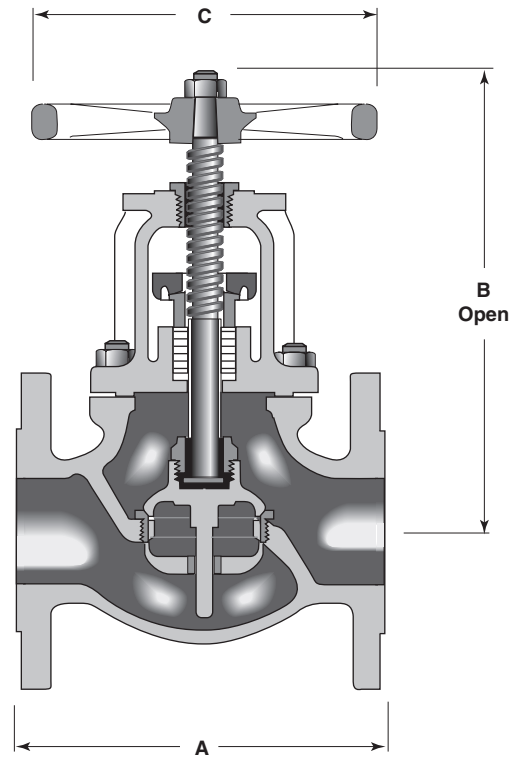

### Principal Parts & Materials

| Fig. No. | Size    | Stem   | Seating | End Conn. |
|----------|---------|--------|---------|-----------|
| 21E      | 2" - 8" | Bronze | Bronze  | Flanged   |

### Dimensions and Weights

Inches (millimeters) - pounds (kilograms)

| Valves | 2<br>(50)      | 2 ½<br>(65)    | 3<br>(80)      | 4<br>(100)     | 6<br>(150)     | 8<br>(200)     |
|--------|----------------|----------------|----------------|----------------|----------------|----------------|
| A      | 10.50<br>(267) | 11.50<br>(292) | 12.50<br>(318) | 14.00<br>(356) | 17.50<br>(445) | 21.00<br>(533) |
| B      | 13.75<br>(349) | 14.75<br>(375) | 16.50<br>(419) | 18.50<br>(470) | 23.25<br>(591) | 28.50<br>(724) |
| C      | 9.00<br>(229)  | 10.00<br>(254) | 10.00<br>(254) | 12.00<br>(305) | 16.00<br>(406) | 20.00<br>(508) |
| Wt.    | 62<br>(28)     | 82<br>(37)     | 118<br>(54)    | 167<br>(76)    | 320<br>(145)   | 570<br>(259)   |