

Figure 1707

1700 Series Bronze Check Valve



Class 125 • Bronze Cap • Brass/Bronze Disc • Threaded Ends

Features

- T-Pattern Swing Check.
- Free-to-rotate bronze disc closes in a different position on the integral seat each time it operates.
- Always install with pressure under the disc in vertical or horizontal position. An arrow cast on the body indicates the correct direction of flow.
- Threaded Ends
- MSS SP-80, Type 3

For more detailed features, refer to page 7.

Figure 1707

Size Range:

¼" through 3"

Working Pressures Non-Shock:

125 psi Steam, Basic Rating

200 psi Cold Working Pressure

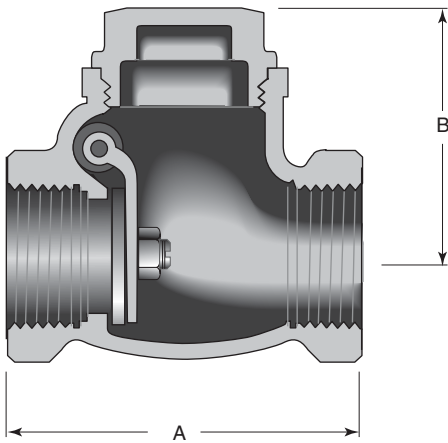

Principal Parts & Materials

Part	Sizes	Material	ASTM
Body	All	Bronze	B62 C83600
Cap	All	Bronze	B16 C83600
Disc	¼" - ¾"	Bronze	B16 alloy 360
Disc	1" - 3"	Bronze	B62 C83600

Dimensions and Weights

Inches (millimeters) - pounds (kilograms)

	¼ (6)	⅜ (10)	½ (15)	¾ (20)	1 (25)	1 ¼ (32)	1 ½ (40)	2 (50)	2 ½ (65)	3 (80)
A	2.12 (54)	2.12 (54)	2.60 (66)	2.76 (70)	3.27 (83)	3.78 (96)	4.25 (108)	5.04 (128)	6.30 (160)	7.08 (180)
B	1.50 (38)	1.50 (38)	1.77 (45)	1.93 (49)	2.28 (58)	2.56 (65)	2.86 (73)	3.50 (89)	4.25 (108)	4.84 (123)
WTS.	0.70 (0.32)	0.70 (0.32)	0.80 (0.36)	1.00 (0.45)	1.40 (0.63)	2.70 (1.22)	2.90 (1.31)	4.40 (1.98)	7.60 (3.42)	9.30 (4.19)