

Class 125 • Inside Screw • Rising Stem • Solid Disc • Threaded Ends

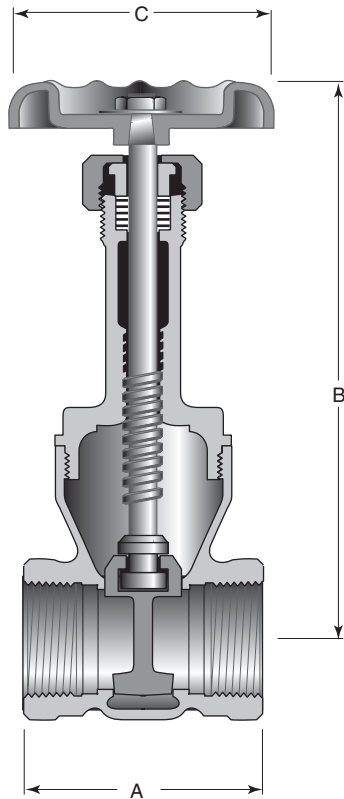

Features

- Rising Stem
- Screwed Bonnet
- Threaded Ends
- Solid Wedge Disc
- Full Ports
- PTFE Packing

For more detailed features, refer to page 7.

Figure 1700

Size Range:

¼" through 3"

Working Pressures Non-Shock:

125 psi Steam, Water, Oil or Gas

200 psi Cold Working Pressure

Principal Parts & Materials

Part	Sizes	Material	ASTM
Body	All	Bronze	B62 C83600
Bonnet	All	Bronze	B62 C83600
Disc	All	Bronze	B62 C83600
Stem	All	Bronze	B584 C83600 or B21C C48200

Dimensions and Weights

Inches (millimeters) - pounds (kilograms)

	¼ (6)	⅜ (10)	½ (15)	¾ (20)	1 (25)	1 ¼ (32)	1 ½ (40)	2 (50)	2 ½ (65)	3 (80)
A	1.65 (42)	1.65 (42)	1.97 (50)	2.00 (51)	2.36 (60)	2.68 (68)	2.78 (71)	3.07 (78)	4.00 (102)	4.57 (116)
B	4.33 (109)	4.33 (109)	4.29 (108)	4.88 (124)	5.98 (152)	6.81 (173)	7.80 (198)	9.53 (242)	11.18 (284)	12.83 (326)
C	1.97 (50)	1.97 (50)	2.17 (55)	2.36 (60)	2.76 (70)	3.15 (80)	3.54 (90)	3.54 (90)	4.72 (120)	5.12 (130)
WTS.	0.50 (0.02)	0.50 (0.02)	0.80 (0.36)	1.10 (0.50)	1.80 (0.81)	2.40 (1.08)	3.20 (1.44)	5.00 (2.25)	10.70 (4.83)	16.80 (7.59)