

300 CWP • Threaded Cap • Brass/Bronze Disc • Solder Ends

Features

- Y-Pattern Body
- Solder Joint Ends
- Always install with pressure under the disc in vertical or horizontal position. An arrow cast on the body indicates the correct direction of flow.
- Screwed Cap
- MSS Specification SP-80

Figure 1342

Size Range:

1/2" through 3"

Working Pressures Non-Shock:

300 psi Cold Working Pressure

For more detailed features, refer to page 48.

Caution: Before installing solder-joint valves, be sure the solder or brazing alloy is compatible with the fluid media and the alloy melting point is high enough to withstand the pressure and temperature conditions. See page 5 for adjusted pressure/temperature ratings.

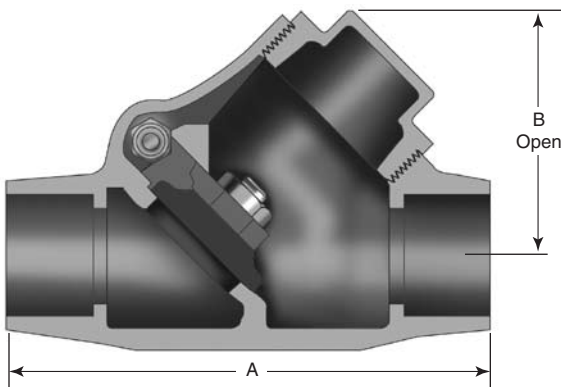

Principal Parts & Materials

Part	Sizes	Material	ASTM
Body	All	Bronze	B62 alloy C83600
Cap	All	Bronze	B61 alloy C92200
Disc	1/2" - 3/4"	Brass	B16 H02
Disc	1" - 3"	Bronze	B61 alloy C92200
Hinge	All	Bronze	B584 alloy C87600
Hinge Pin	All	Stainless Steel	18-8

Dimensions and Weights

Inches (millimeters) - pounds (kilograms)

	1/2 (15)	3/4 (20)	1 (25)	1 1/4 (32)	1 1/2 (40)	2 (50)	2 1/2 (65)	3 (80)
A	2.70 (69)	3.61 (92)	4.25 (108)	4.82 (122)	5.60 (142)	6.86 (174)	7.78 (198)	9.31 (236)
B	1.61 (41)	1.92 (49)	2.50 (64)	2.84 (72)	3.47 (88)	4.17 (106)	5.00 (127)	5.90 (150)
WTS.	0.70 (0.32)	1.10 (0.50)	1.80 (0.82)	2.50 (1.13)	4.10 (1.86)	6.40 (2.90)	10.60 (4.81)	15.90 (7.21)