

300 CWP • Union Bonnet • Rising Stem • Solder Ends

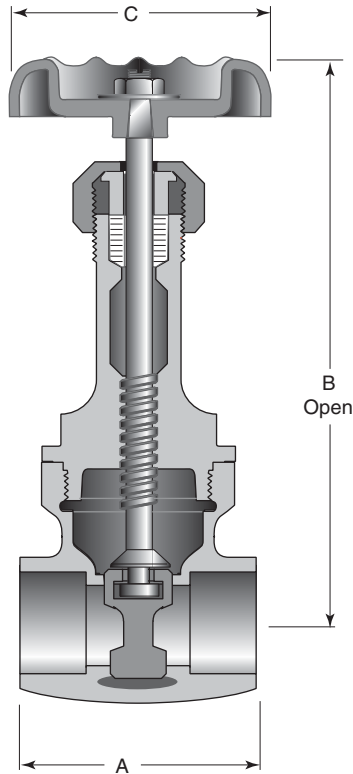

Features

- Screwed One Piece Bonnet
- Solid Wedge Disc
- Solder Joint Ends
- Full Ports
- Back Seat
- Integral Bronze Seat
- MSS SP-80, Type 2

For more detailed features, refer to page 18.

Caution: Before installing solder-joint valves, be sure solder or brazing alloy melting point is high enough to withstand line pressure, temperature conditions, and is compatible with fluid medium. See page 5 for adjusted pressure/temperature ratings.

Figure 1334

Size Range:

3/8" through 3"

Working Pressures Non-Shock:

300 psi Cold Working Pressure

Principal Parts & Materials

Part	Size	Material	ASTM
Body & bonnet	All	Bronze	B62 alloy C83600
Disc	All	Bronze	B62 alloy C83600
Stem	3/8"-2"	Bronze	B505 alloy C83600
Stem	2 1/2"-3"	Bronze	B371 alloy C69400

Dimensions and Weights

Inches (millimeters) - pounds (kilograms)

	3/8	1/2	3/4	1	1 1/4	1 1/2	2	2 1/2	3
	(10)	(15)	(20)	(25)	(32)	(40)	(50)	(65)	(80)
A	1.56 (40)	1.89 (48)	2.40 (61)	2.90 (74)	3.11 (79)	3.50 (89)	4.14 (105)	4.93 (125)	5.99 (152)
B	4.93 (125)	5.07 (129)	6.26 (159)	7.38 (187)	8.49 (216)	10.06 (256)	11.82 (300)	14.56 (370)	16.81 (427)
C	1.96 (50)	2.07 (53)	2.57 (65)	2.76 (70)	3.07 (78)	3.66 (93)	4.00 (102)	5.24 (133)	5.24 (133)
WTS.	0.70 (0.32)	0.80 (0.34)	1.30 (0.59)	2.00 (0.91)	3.10 (1.38)	4.40 (2.00)	6.30 (2.84)	12.20 (5.51)	18.00 (8.14)